

JAM NUT RECEPTACLES

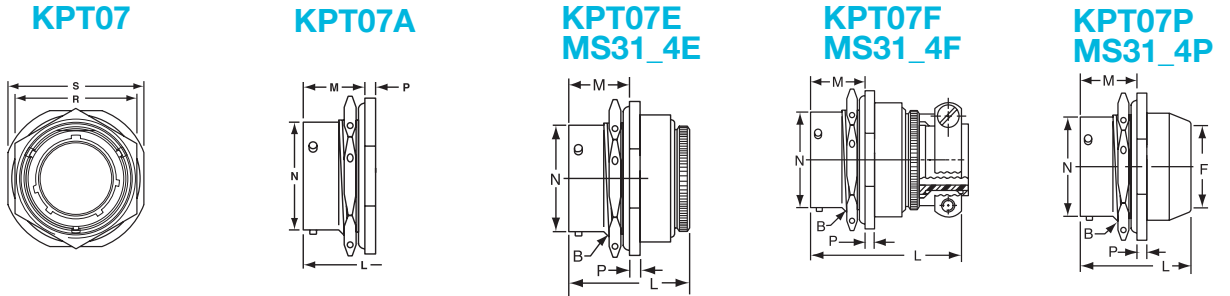

SHELL SIZE	B THREAD UNEF -2A	07					PANEL THICKNESS		07A L MAX.	07E/F		07P	
		M +/- 0.031 (0.79)	N +/- 0.003 (0.08)	P +/- 0.020 (0.51)	R	S	MIN.	MAX.		STYLE E L MAX.	STYLE F L MAX.	F	L
8	.5625-24	0.691 (17.6)	0.471 (12.0)	0.117 (3.0)	0.750 (19.1)	0.954 (24.2)	0.062 (1.6)	0.125 (3.2)	0.889 (22.6)	1.344 (34.1)	1.906 (48.4)	0.317 (8.1)	1.391 (35.3)
10	.6875-24	0.691 (17.6)	0.588 (14.9)	0.117 (3.0)	0.875 (22.2)	1.078 (27.4)	0.062 (1.6)	0.125 (3.2)	0.889 (22.6)	1.344 (34.1)	1.906 (48.4)	0.434 (11.0)	1.391 (35.3)
12	.8750-20	0.691 (17.6)	0.748 (19.0)	0.117 (3.0)	1.062 (27.0)	1.266 (32.2)	0.062 (1.6)	0.125 (3.2)	0.889 (22.6)	1.344 (34.1)	1.906 (48.4)	0.548 (13.9)	1.391 (35.3)
14	1.0000-20	0.691 (17.6)	0.873 (22.2)	0.117 (3.0)	1.188 (30.2)	1.391 (35.3)	0.062 (1.6)	0.125 (3.2)	0.889 (22.6)	1.344 (34.1)	1.906 (48.4)	0.673 (17.1)	1.391 (35.3)
16	1.1250-18	0.691 (17.6)	0.988 (25.1)	0.117 (3.0)	1.312 (33.3)	1.516 (38.5)	0.062 (1.6)	0.125 (3.2)	0.889 (22.6)	1.344 (34.1)	2.047 (52.0)	0.798 (20.3)	1.391 (35.3)
18	1.2500-18	0.691 (17.6)	1.123 (28.5)	0.117 (3.0)	1.438 (36.5)	1.641 (41.7)	0.062 (1.6)	0.125 (3.2)	0.889 (22.6)	1.344 (34.1)	2.078 (52.8)	0.899 (22.8)	1.391 (35.3)
20	1.3750-18	0.879 (22.3)	1.248 (31.7)	0.148 (3.8)	1.562 (39.7)	1.828 (46.4)	0.062 (1.6)	0.250 (6.4)	1.108 (28.1)	1.594 (40.5)	2.328 (59.1)	1.024 (26.0)	1.641 (41.7)
22	1.5000-18	0.879 (22.3)	1.373 (34.9)	0.148 (3.8)	1.688 (42.9)	1.954 (49.6)	0.062 (1.6)	0.250 (6.4)	1.108 (28.1)	1.594 (40.5)	2.328 (59.1)	1.149 (29.2)	1.641 (41.7)
24	1.6250-18	0.912 (23.2)	1.498 (38.0)	0.148 (3.8)	1.812 (46.0)	2.078 (52.8)	0.062 (1.6)	0.250 (6.4)	1.141 (29.0)	1.641 (41.7)	2.453 (62.3)	1.274 (32.4)	1.703 (43.3)

PANEL CUTOUTS/THICKNESS

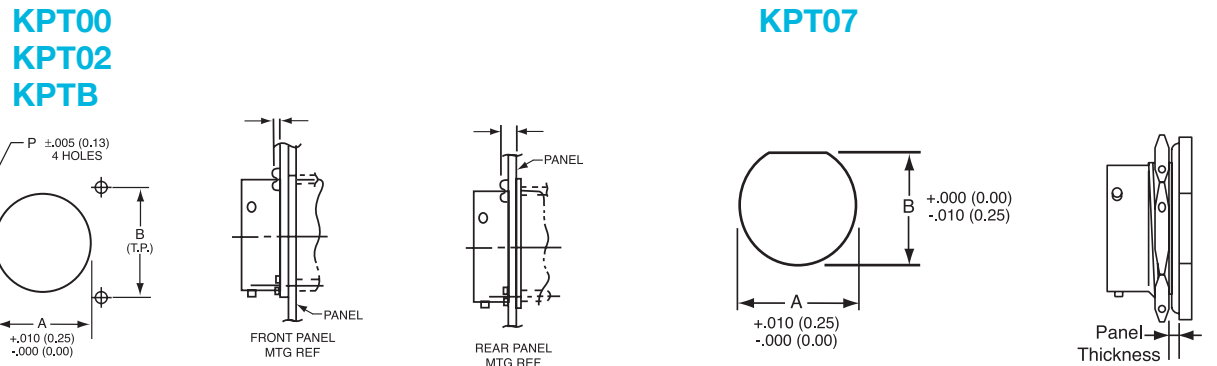

SHELL SIZE	A	B	P +/- .005	SCREW SIZE	PANEL THICKNESS	
					KPT/KPSE 00/02	KPTB
8	0.618 (15.7)	0.594 (15.1)	0.125 (3.2)	#4	0.087 (2.2)	0.218 (5.5)
10	0.735 (18.7)	0.719 (18.3)	0.125 (3.2)	#4	0.087 (2.2)	0.218 (5.5)
12	0.859 (21.8)	0.812 (20.6)	0.125 (3.2)	#4	0.087 (2.2)	0.218 (5.5)
14	0.985 (25.0)	0.906 (23.0)	0.125 (3.2)	#4	0.087 (2.2)	0.218 (5.5)
16	1.113 (28.3)	0.969 (24.6)	0.125 (3.2)	#4	0.087 (2.2)	0.218 (5.5)
18	1.235 (31.4)	1.062 (27.0)	0.125 (3.2)	#4	0.087 (2.2)	0.218 (5.5)
20	1.361 (34.6)	1.156 (29.4)	0.125 (3.2)	#4	0.212 (5.4)	0.334 (8.5)
22	1.485 (37.7)	1.250 (31.8)	0.125 (3.2)	#4	0.212 (5.4)	0.334 (8.5)
24	1.611 (40.9)	1.375 (34.9)	0.155 (3.9)	#6	0.212 (5.4)	0.311 (7.9)

SHELL SIZE	A +010-.000 (+.25-.00)	B +.000-.010 (+.00-.25)	PANEL THICKNESS	
			MIN.	MAX.
8	0.578 (14.7)	0.540 (13.7)	0.062 (1.6)	0.125 (3.2)
10	0.703 (17.9)	0.665 (16.9)	0.062 (1.6)	0.125 (3.2)
12	0.890 (22.6)	0.828 (21.0)	0.062 (1.6)	0.125 (3.2)
14	1.015 (25.8)	0.952 (24.2)	0.062 (1.6)	0.125 (3.2)
16	1.140 (29.0)	1.076 (27.3)	0.062 (1.6)	0.125 (3.2)
18	1.265 (32.1)	1.201 (30.5)	0.062 (1.6)	0.125 (3.2)
20	1.390 (35.3)	1.326 (33.7)	0.062 (1.6)	0.250 (6.4)
22	1.515 (38.5)	1.451 (36.9)	0.062 (1.6)	0.250 (6.4)
24	1.640 (41.7)	1.576 (40.0)	0.062 (1.6)	0.250 (6.4)

All dimensions in inches (millimeters in parentheses) unless otherwise stated.