



USBF TV (USB-A)

USB Connection System for Harsh Environment



With USB Field, you can insert a standard USB 2.0 cordset into a metallic plug which will protect it from shocks, dust and fluids.

No hazardous on-field cabling and grounding!

This metallic plug is connected into a receptacle, using a Tri Start Thread coupling mechanism (MIL-DTL-38999 series III type) with anti-decoupling device for high vibrations.

Applications

- Embedded Computers
- Data Acquisition and transmission in harsh environment
- Railways
- Battelfield Communication Systems
- Navy Systems

Data Transmission

USB Specification 2.0
Data Rate: Up to 480 Mb/s for High Speed USB

MAIN CHARACTERISTICS

- Sealed against fluids and dusts (IP68)
- Shock, Vibration and Traction resistant
- No cabling operation in field and no tools required
- Improved EMI protection
- Tri Start Thread coupling mechanism (MIL-DTL-38999 series III type) with anti-decoupling device
- 2 mechanical Coding / Polarization possibilities by the user (receptacle insert rotation)
- USBF TV plug retention in the receptacle: 100 N in the axis
- Mating cycles: 500 to 1500

Environmental Protection

- Sealing (when mated): IP68 (Temporary immersion)
- Salt Spray: 48 h with Nickel plating
> 500 h with Olive Drab Cadmium
1000 h with marine bronze shell
- Fire Retardant / Low Smoke: UL94 V0 and NF F 16 101 & 16 102
- Vibrations: 10 – 500 Hz, 10 g, 3 axes: no discontinuity > 1micro s
- Shocks: IK06: weight of 250 g drop from 40 cm [15.75 in] onto connectors (mated pair)
- Humidity: 21 days, 43°C, 98% humidity
- Temperature Range: - 40°C / +85°C

Part Number Code

Series	USBF TV	2	1	G
USB Field TV				
Shell Type				
6:	Plug			
2:	Square flange receptacle			
2PE:	Square flange receptacle with metal backshell (type 1) & with metal backshell + plastic gland (type 2)			
2PEM:	Square flange receptacle with backshell + metal gland (only for back termination type 2 = Solder)			
7:	Jam nut receptacle			
7PE:	Jam nut receptacle with metal backshell (type 1) & with metal backshell + plastic gland (type 2)			
7PEM:	Jam nut receptacle with backshell + metal gland (only for back termination type 2 = Solder)			
Back Terminations (Receptacles only)				
1:	Female USB-A			
2:	Solder (4 tinned holes)			
Shells Material & Finish				
N:	Aluminium shell - Nickel plating - ROHS compliant			
G:	Aluminium shell - Olive Drab Cadmium plating			
BZ:	Marine bronze shell - ROHS compliant			

- Examples:
- Olive Drab Cadmium Plug: USBF TV 6G
 - Olive Drab Cadmium Square Flange Receptacle, USB-A back terminat°: USBF TV 21G
 - Olive Drab Cadmium Jam Nut Receptacle, USB-A receptacle back terminat°: USBF TV 71G
 - Nickel Jam Nut Receptacle, solder termination: USBF TV 72N

Amphenol USBF TV

Plug

- Shell type 6

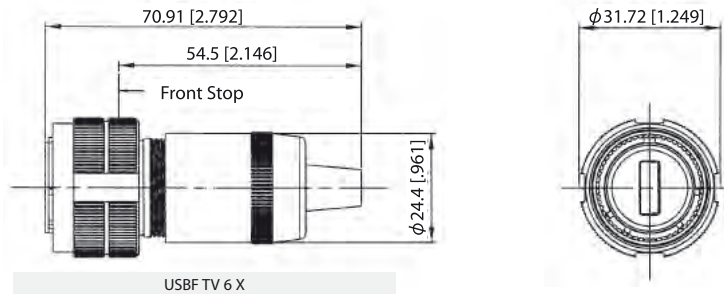

Receptacles

- Square flange receptacle
4 mounting holes: Shell type 2

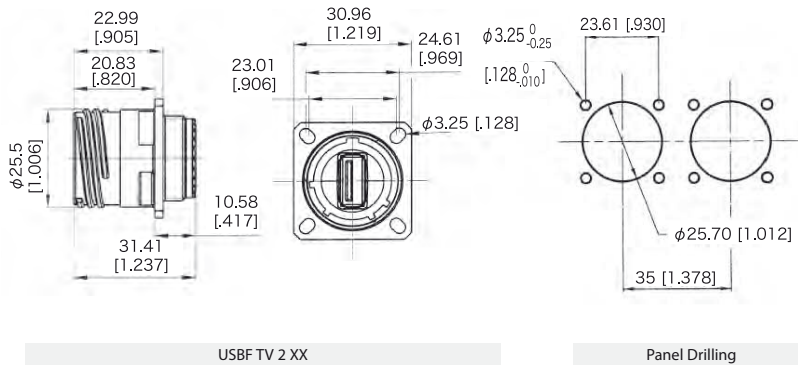

- Jam nut receptacle
Hexagonal Nut mounting:
Shell type 7

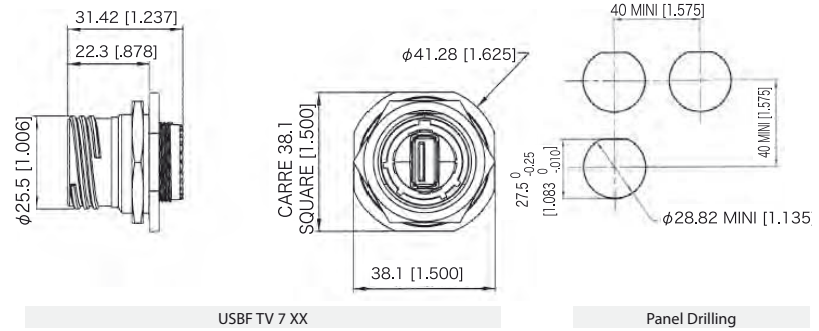

- Receptacles with backshell
Shell type 2PE and 7PE

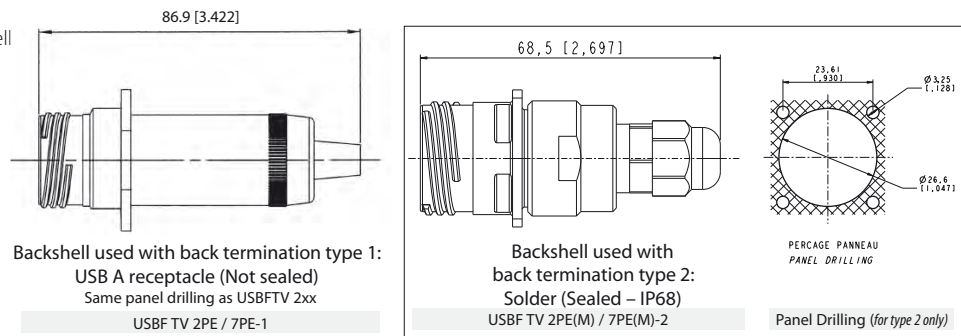

Back Terminations

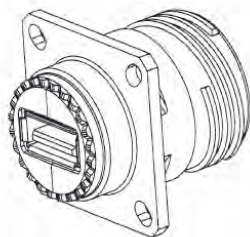

Type 1: Female USB-A

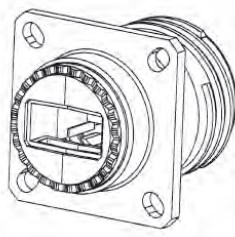

Type 2: Solder 4 Tinned holes to solder your cable

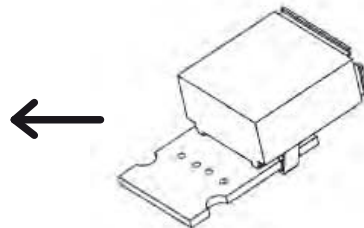

View of the PCB of the Type 2 version with 4 tinned holes for solder termination

Assembly Instructions

Can be used with most the USB cordset brands: No tools required!

Plug Assembly

1. Only if you need a full sealing (IP68): Install the white sticker around the plug, covering the 4 little holes of the overmolding
2. Insert the black O Ring around the front face of the USB A plug. This O Ring will ensure connection sealing
3. Insert the USB cordset into the metallic backshell
4. Insert the retention spacer laterally to the cable (this spacer is soft, in order to adapt to different shapes of overmolding) and slide the overmolding of the USB-A plug into this retention spacer
5. Insert the friction ring laterally to the cable
6. Choose the right coding (2 positions) and insert the USB-A plug into the protective plug. Note at this step, the main key is used for polarization.

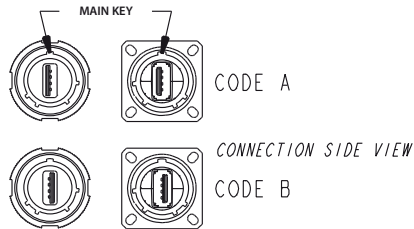

7. Screw the backshell on the plug body. A wrench can be necessary to fully tighten it, and the connection to the receptacle can help

IMPORTANT NOTE

The connection sealing is not done by the black retention spacer (which is slotted), but by the front face ORing (fig. 2)

Receptacle Assembly

Insert the USB module from the rear. Reference is main key. Beware to have a coding compatible with the coding you used for the plug: on front view, the white shapes in the USBs must be on the same side.

To remove the USB module, insert the removal tool **USBF ODE** from the front, and push back the module.

Accessories

■ Metallic Caps

	USBF TVC	2	G
Connector Type			
6:	Plug		
2:	Square Flange Receptacle		
7:	Jam Nut Receptacle		
Shells Material & Finish			
N:	Aluminium shell - Nickel - ROHS compliant		
G:	Aluminium shell - Olive Drab Cadmium		
BZ:	Marine bronze shell - ROHS compliant		

- Panel Gasket for square flange receptacle (Thickness: 0,8 mm [.031]): JE15



- Receptacle Insert removal tool: USBF ODE

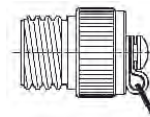

Plug Cap



Receptacle Cap

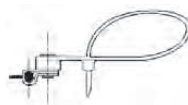

Plug Cap end

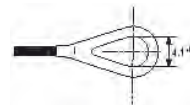

Square flange receptacle cap end

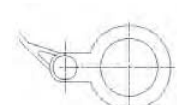

Jam Nut receptacle cap end



USBF TV

Self Closing Cap (SCC Series)



This Self Closing cap automatically protects the USBF TV (type A) & USBBF TV (type B) square flange receptacles (MIL-DTL-38999 type), protecting your system from dust and water projection. A spring automatically closes the upper part of the cap when the USB plug is removed from the receptacle.

IMPORTANT NOTE

Metal Self Closing cap are sold separately (without receptacle)

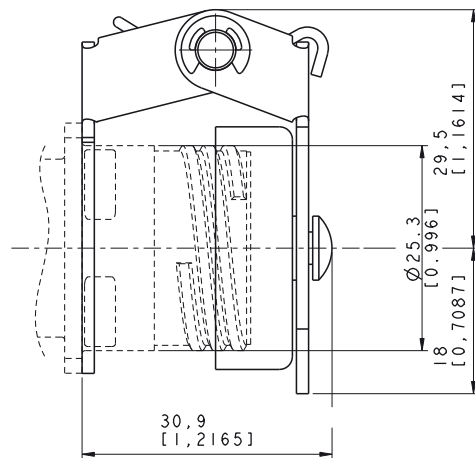
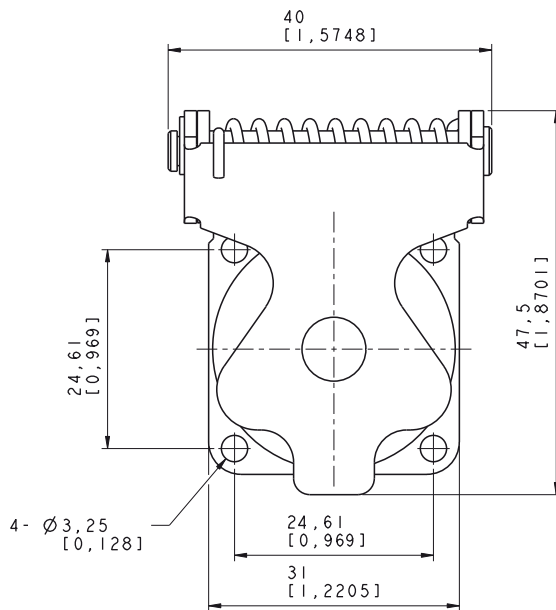

- Panel Gasket for square flange receptacle (Thickness: 0,8 mm [.031]):

PART NUMBER: JE15



PART NUMBER:

Self closing cap: **USBFTVSCC**

Remark: Compatible with USBFTV (type A) & USBBF TV (type B) square flange receptacles only:
USBFTV2XX (see page 25)
USBBF TV2XX (see page 37)



USBF TV

Transversally Sealed Receptacle



SEALED RECEPTACLE In some applications, a transversal sealing for the receptacle is a « must ». This will prevent fluids and dust from going through the receptacle when plug or cap are not mated to the receptacle. The sealed solution (version "S") has a compound at the rear of the receptacle below. In addition, the Sealed USBF TV has been successfully tested in very high vibration corresponding to airplane applications.

Applications

- Embedded Computers
- Data Acquisition and transmission in harsh environment
- Railways
- Battelfield Communication Systems
- Navy Systems

MAIN CHARACTERISTICS

- Sealed against fluids and dusts (IP68)
- Shock, Vibration and Traction resistant
- No cabling operation in field and no tools required
- Improved EMI protection
- Tri Start Thread coupling mechanism (MIL-DTL-38999 series III type) with anti-de-coupling device
- 2 mechanical Coding / Polarization possibilities by the user (receptacle insert rotation)
- USBF TV plug retention in the receptacle: 100 N in the axis
- Mating cycles: 500 to 1500

Data Transmission

USB Specification 2.0
Data Rate: Up to 480 Mb/s for High Speed USB

Environmental Protection

- Sealing (when mated): IP68 (Temporary immersion)
- Salt Spray: 48 h with Nickel plating
> 500 h with Olive Drab Cadmium
1000 h with marine bronze shell
- Fire Retardant / Low Smoke: UL94 V0 and NF F 16 101 & 16 102
- Vibrations: 10 – 500 Hz, 10 g, 3 axes: no discontinuity > 1 micro s
- Shocks: IK06: weight of 250 g drop from 40 cm [15.75 in] onto connectors (mated pair)
- Humidity: 21 days, 43°C, 98% humidity
- Temperature Range: - 40°C / +85°C

Part Number Code

Series	USBF TV	2PES	A	2	N	03	A
USB Field TV							
Shell Type							
2S:	Square flange receptacle						
2PES:	Square flange receptacle + backshell + plastic gland						
2PEMS:	Square flange receptacle + backshell + metal gland						
7S:	Jam nut receptacle						
7PES:	Jam nut receptacle + backshell + plastic gland						
7PEMS:	Jam nut receptacle + backshell + metal gland						
Coding							
"A" (Standard) or "B"							
Back Terminations							
2:	Rugged USB cable (see corresponding datasheet page 42)						
Shells Plating							
N:	Nickel						
G:	Olive drab cadmium plating						
USB cable length							
03:	30 cm [11.81 inches]						
05:	50 cm [19.68 inches]						
10:	1 meter [39.37 inches]						
USB cable end							
A:	Standard USB-A plug						
OPEN:	Open cable (no connector)						

Receptacles

- Square flange receptacle
4 mounting holes: Shell type 2

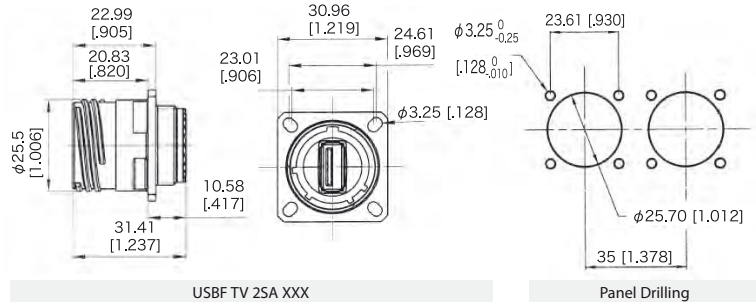

USBF TV 2SA XXX

Panel Drilling

- Jam nut receptacle
Hexagonal Nut mounting:
Shell type 7

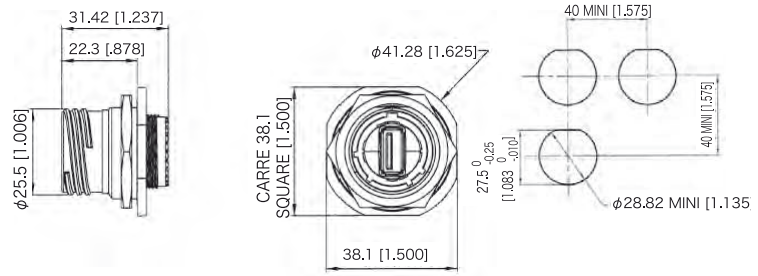

USBF TV 7SA XXX

Panel Drilling

- Receptacles with backshell:
Shell type 2PE(M) and 7PE(M)

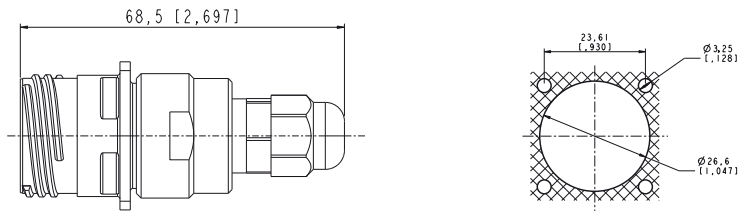

Backshell used with
back termination type 2:
Solder (Sealed - IP68)

USBF TV 2PE(M) SA2XXX / USBF TV 7PE(M) SA2 XXX

PERCAGE PANNEAU
PANEL DRILLING

Panel Drilling

Cordset End

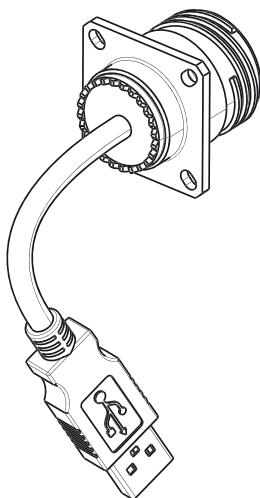

USB Cable end type "A"

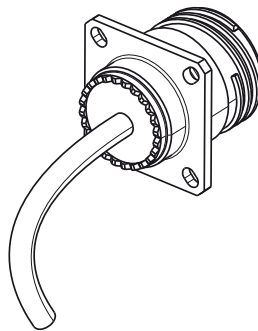

USB Cable type "OPEN"



USBFTV

Receptacles with 360° EMI backshells stand off receptacles



USBFTV Receptacles series with EMI backshells provide 360° shielding: same protection than the one proposed per Standard MIL-DTL-38999 serie III Connectors. We offer these EMI backshells with square flange and jam nut receptacles. The available platings are nickel or olive drab cadmium. With those solutions we suggest using our reinforced USB cable (shielded – zero halogen jacket). See page 33.

We can provide those receptacles:

- with cordset already soldered
- without cordset

RECEPTACLES WITH 360° EMI BACKSHELLS

EXAMPLE WITH A SQUARE FLANGE RECEPTACLE (PROVIDED WITHOUT CABLE)

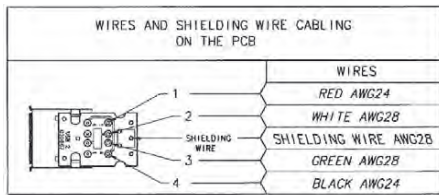
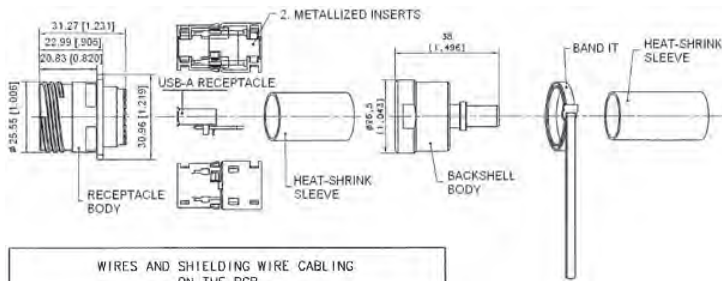

PART NUMBERS:

- Jam nut receptacle – Nickel: **KIT40245**
- Jam nut receptacle – Olive Drab Cadmium: **KIT40245G**
- Square flange receptacle – Nickel: **KIT40263**
- Square flange receptacle – Olive Drab Cadmium: **KIT40263G**

IMPORTANT NOTE

With receptacles provided without cable, customer will have to solder his cable on the PCB, please find below the cabling specification. If customer prefers to use his cable, please check with us compatibility with our EMI backshells:

www.usbfield.com

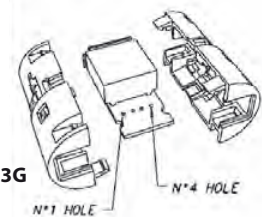

USB FTV - special

Amphenol



STAND OFF RECEPTACLE

Those receptacles can be soldered directly on your PCB. A compound insures a transversal sealing and good performance in high-vibration environments. The shell of these receptacles are in the « Stand Off » style. They can be connected with rugged USBFTV series plugs.

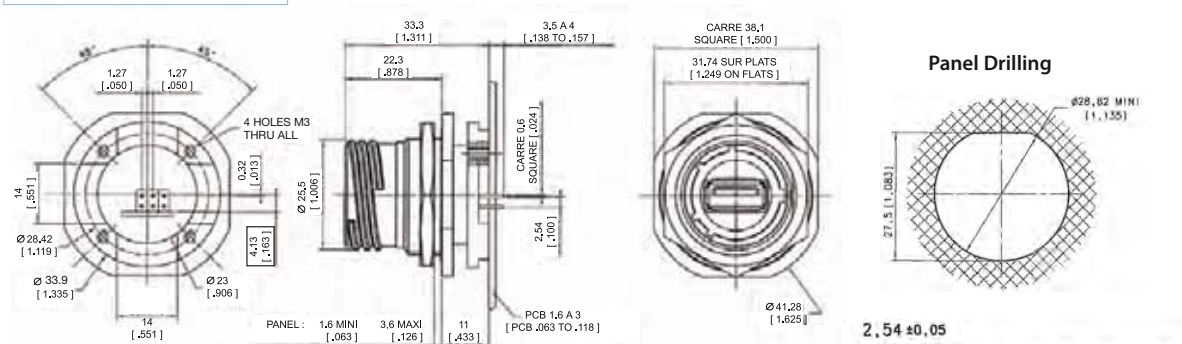

PART NUMBERS:

- Jam nut receptacle – Nickel: **USBFTV75NF459** (coding "A")
- Jam nut receptacle – Olive Drab Cadmium: **USBFTV75GF459** (coding "A")
- Square flange receptacle – Nickel: **USBFTV25NF459** (coding "A")
- Square flange receptacle – Olive Drab Cadmium: **USBFTV25GF459** (coding "A")

