

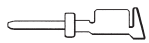

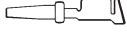





## DIMENSIONS

16-20 AWG	PINS FOR RECEPTACLES	SOCKETS FOR PLUGS	CRIMP TOOL	STRIP LENGTH	WIRE SEALING RANGE	WIRE HOLE FILLER	EXTRACTION TOOL
LOOSE	030-2464-007 	030-2480-000  030-2480-007 HOODED	112108-0007 	.210 - .220 IN (5.33-5.99MM) 	.095 - .130 IN (2.42-3.30MM) 	225-0093-000 	274-7068-001 
REEL OF 4500 PCS.	110238-0446 	110238-0488  110238-1016 HOODED	AUTOMATIC/ SEMI-AUTOMATIC PLEASE CONTACT US				323-9519-000 REPLACEMENT TIP 

### S2 PLUG

#### WITH FLANGE ENDBELL (PLUG ONLY)

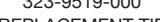
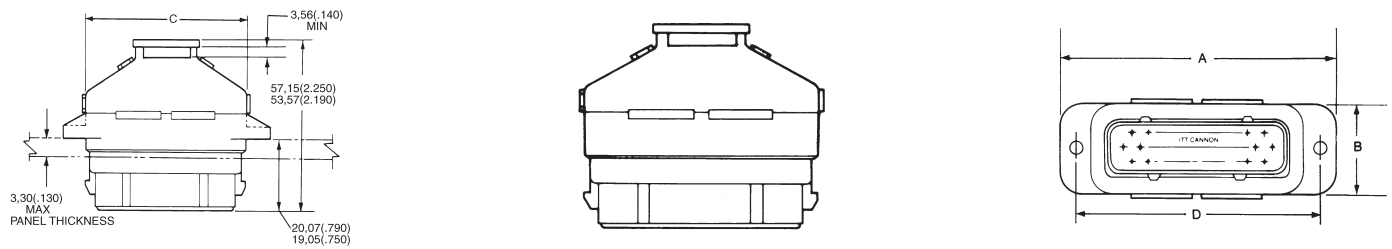

NO. OF CONTACTS	PART NUMBER BY SHELL SIZE	A MAX.	B MAX.	C MAX.	D ±0.38 (.015)
19	SLEB	71.88 (2.830)	26.16 (1.030)	47.50 (1.870)	59.05 (2.325)
28	SLEC	87.11 (3.430)	26.16 (1.030)	62.74 (2.470)	74.29 (2.925)

### P4 RECEPTACLE

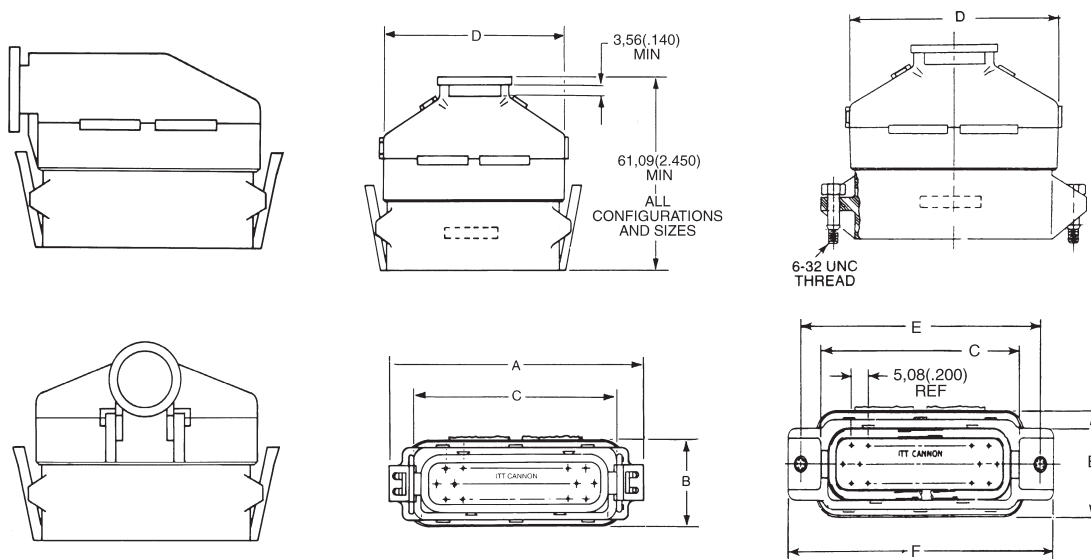

NO. OF CONTACTS	PART NUMBER BY SHELL SIZE	A MAX.	B MAX.	C MAX.	D MAX.	E ±0.38 (.015)	F MAX.
19	SLEB	59.44 (2.340)	26.16 (1.030)	44.07 (1.735)	50.58 (2.000)	55.87 (2.200)	64.25 (2.530)
28	SLEC	76.45 (3.010)	26.16 (1.030)	59.31 (2.335)	66.04 (2.600)	71.11 (2.800)	79.49 (3.130)

All dimensions in mm (inches) unless otherwise stated.

PRINTED CIRCUIT BOARD PLUG

T3 STRAIGHT

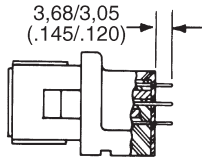
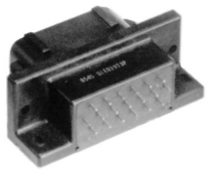

N3 RIGHT ANGLE

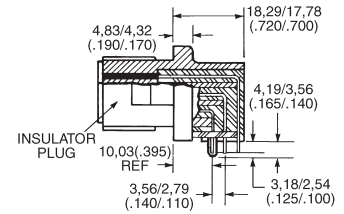

19 CONTACTS

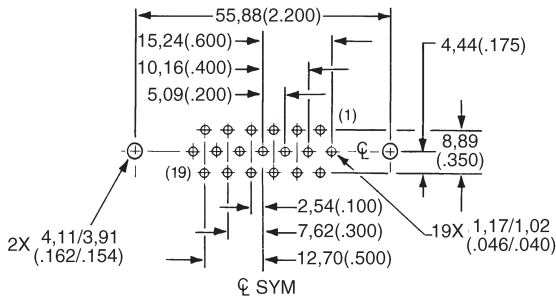

19 CONTACTS

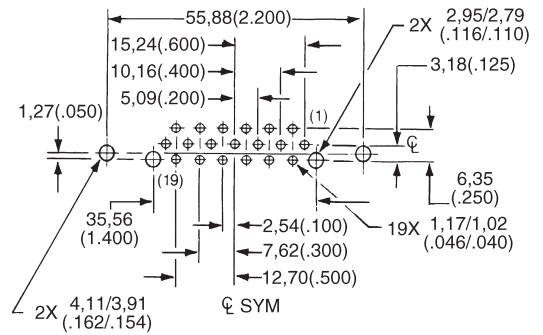

28 CONTACTS

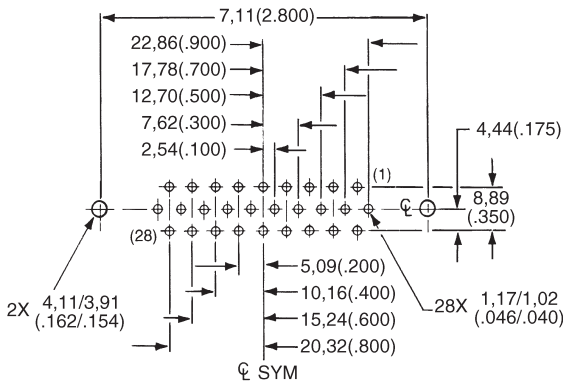

28 CONTACTS

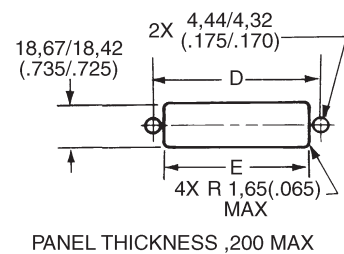
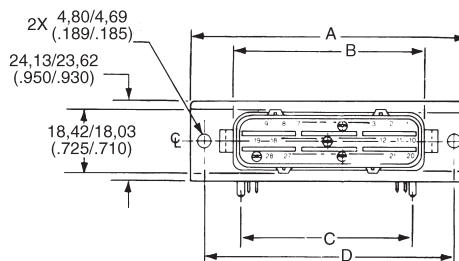
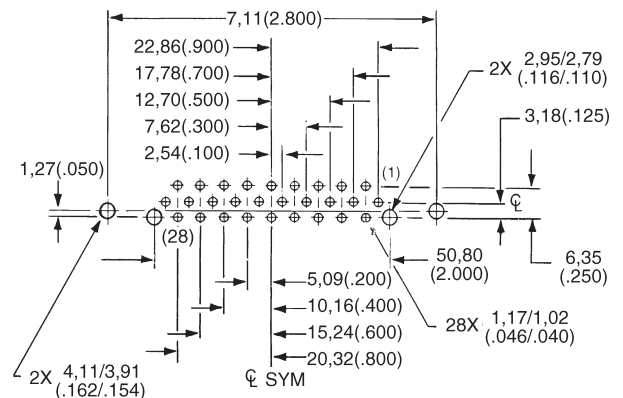

NO. OF CONTACTS	PART NUMBER BY SHELL SIZE	A MAX.	B MAX.	C MAX.	D ±.38 (.015)	E MAX.
19	SLEB	64.25 (2.530)	44.07(1.735)	35.81 (1.410)	55.87 (2.200)	47.62 (1.875)
28	SLEC	79.49 (3.130)	59.31 (2.335)	51.05 (2.010)	71.11 (2.800)	62.86 (2.475)

All dimensions in mm (inches) unless otherwise stated.

## DIMENSIONS

### CONTACT ARRANGEMENT

#### FACE VIEW – ENGAGING FACE OF PLUG

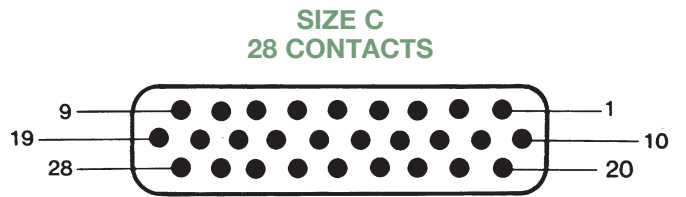
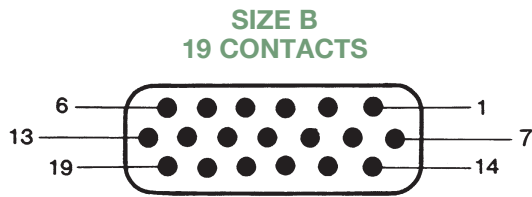

### ENDBELLS

#### FLANGE MOUNT – (F)

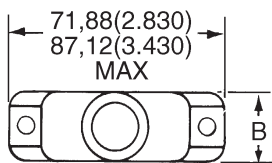

#### STRAIGHT – (S)

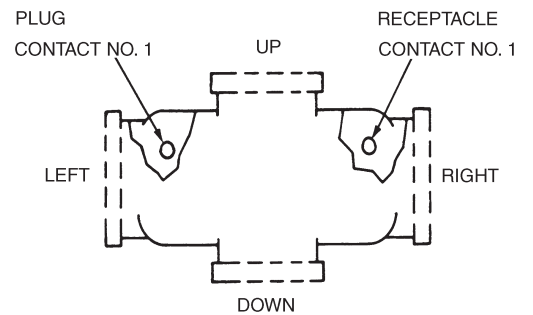
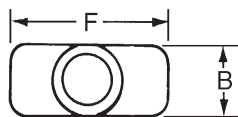

Other Endbell Views (From Rear)  
“B” and “F” dimensions are the same for all SLE endbells

PART NUMBER BY SHELL SIZE	B MAX.	F MAX.	CABLE ENTRY I.D.
SLEB	26.16 (1.030)	50.80 (2.000)	14.73 (.580)
SLEC	26.16 (1.030)	66.04 (2.600)	19.81 (.780)

### POLARIZATION

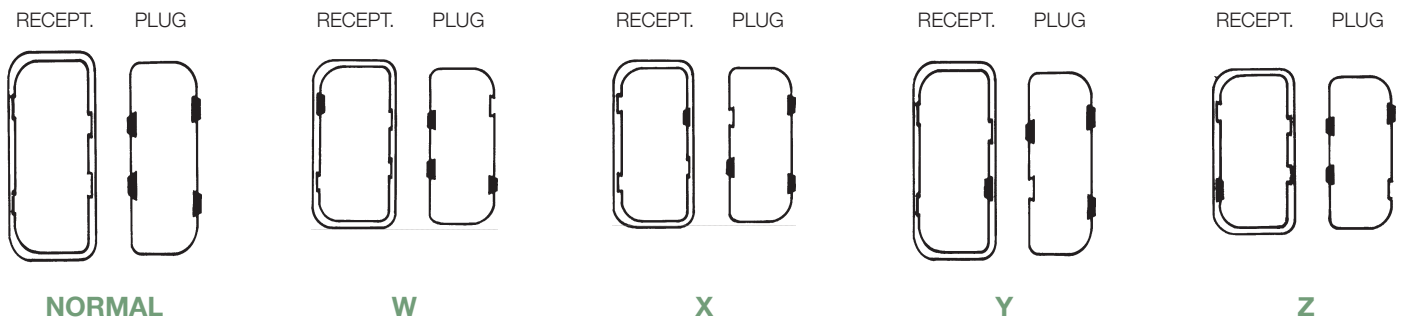

Keys can be moved / removed.

All dimensions in mm (inches) unless otherwise stated.