

cannon

Mini Circular Series



ITT

ENGINEERED FOR LIFE

ITT Mini Circular Series

ITT Cannon continues its long legacy of connector innovation with the introduction of its new mini circular connector range; this innovative new range not only satisfies market requirements for intense ruggedization but is also suitable for the harshest environments known to man.

The range addresses the need for increased miniaturization in both man worn and hand held equipment; it offers high levels of both sealing capability and contact durability.

The new mini circular range can achieve an equipment size reduction of up to 60% together with a weight reduction of up to 71% whilst maintaining the same overall level of performance and reliability as larger and heavier connectors *

ITT Cannon's new mini circular connector range provides unparalleled functionality for numerous applications across multiple markets including Industrial, Defense, Aerospace and Medical. It demonstrates the high quality and performance that the Cannon brand is renowned for.

*When compared to the 38999 size 22 layout.



Defense



Industrial



Medical



First Responder

Example Application Areas

- Defence
 - Ear Phones
 - Radios
 - GPS
 - Weapons
 - Computers
 - Head Sets
 - Vision Systems
 - Communication Systems
 - Batteries
 - PDA's
- Industrial
 - Ruggedized Computers
 - Hand Held Data Terminals
 - Process Control Equipment
 - Display Equipment
- Medical
 - Surgeons Equipment
 - Patient Monitoring Equipment
 - Surgery Equipment
 - Diagnostic Equipment
- First Responder
 - Radios
 - Vision Systems
 - GPS
 - Head Sets
 - Cameras

Delivering reduction in weight and size without loss of reliability.



The ITT Cannon family of mini circular connectors provides equivalent or exceeds the electrical and mechanical characteristics of larger and heavier Military Standard Environmental connectors.

Why customers benefit from choosing ITT's Mini Circular Series

- ITT Cannon pogo contact technology
- Blind mating design
- RoHS plating meeting the latest environmental standards
- Human factors design considerations
- Rugged construction
- Enhanced strain relief design
- 500 hour salt spray resistant plating
- Sealed in the mated and un-mated conditions



Lowest possible profile

Taking interconnect profiles to a minimum level, our industry leading "no profile" "Space Saver" variant enables the lowest possible profile for ruggedized, wearable equipment.

No profile



High Density Connector

Connector uses size 23 contacts accepting #22 to #28 wire. Contacts spacing is reduced to 0.076 inches providing a compact yet robust package.



Draw back barrel design

Nemesis "Super Clean" provides the ultimate in cleanability with its unique patented draw back barrel design, allowing the user to retract, clean, and reconnect in seconds.



Spring "breakaway" technology

Our canted spring "breakaway" technology allows for effective and "tuned" interconnect disconnecting while providing a full 360 degrees of EMI shielding.



Pogo pad receptacle technology

The Nemesis pogo pad receptacle technology removes the harsh environment "fouling" common to non-pad receptacles. Further, this exciting technology removes the need for receptacle dust-caps.

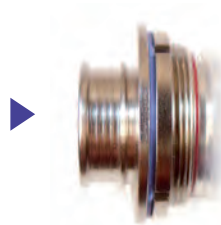

Integral Band Platform

Integral band platform allows direct attachment of cable shield to the connector.



Superior overmolding techniques

Seamless and superior overmolding techniques ensure sealability and integrity of the connector shell and cable interface, even within the most demanding environments.



Fast & efficient assembly

Nemesis "Quick Term" and "Quick Term High Speed" enables fast & efficient assembly of cable harnesses using normal work tools in the field.

Mini Circular Series Catalogue

Selector Guide



Series	Nemesis Quick Term	Nemesis Quick Term High Speed	Cannon Break Away
Product Classification	Commercial	Commercial	Commercial
Coupling System	Snap-on/Breakaway	Snap-on/Breakaway	Snap-on/Breakaway
Maximum Temperature Range	-55° to +125°C	-55° to +125°C	-55° to +150°C
Hardware	Stainless Steel	Stainless Steel	Stainless Steel & Aluminium
Finishes	Black Electroless Nickel & Electroless Nickel	Black Electroless Nickel & Electroless Nickel	Black Zinc Nickel & Electroless Nickel
Contact Type	Solder Bucket	Solder Bucket & Straight PCB Tails	Solder Bucket & PCB Tails
Contacts	Pogo Pins & Pads	Pogo Pins & Pads	Pogo Pins & Pads
Contact Plating	Gold over Nickel	Gold over Nickel	Gold over Nickel
Layouts	7, 14 & 19 way	8, 14 & 19 way	3, 4, 7, 10, 19 & 37 way
Wire Size	22 - 32 AWG	22 - 32 AWG	22 - 28 AWG
Cable	Customer Terminated or Factory Fitted	Customer Terminated or Factory Fitted	Customer Terminated or Factory Fitted
Contact Rating	2 Amps continuous, 3 Amps peak	2 Amps continuous, 3 Amps peak	2 Amps continuous, 3 Amps peak
Contact Resistance	15 mOhm	15 mOhm	15 mOhm
Voltage Rating	50 Volts DC	50 Volts DC	500 VAC
Dielectric Withstand Voltage Sea Level	500 Volts	500 Volts	750 VAC
Insulation Resistance	5 Gohm min (1 Gohm after immersion)	5 Gohm min (1 Gohm after immersion)	5,000 MOhm
Mating Cycles	10,000	10,000	10,000
Coding	5 clocking positions: N, A, B, C & D	5 clocking positions: N, A, B, C & D	4 clocking positions: A, B, C & D
RoHS Compliance	Yes	Yes	Yes
Sealing	IP67	IP67	IP67
Page No.	6	9	16



Nemesis Space Saver	Nemesis Super Clean	Nemesis High Mating	Nemesis Water Tight
Commercial	Commercial	Commercial	Commercial
Snap-on/Ripaway	Snap-on/Breakaway	Snap-on/Breakaway	Snap-on/Breakaway & Push Pull
-55° to +125°C	-55° to +125°C	-55° to +125°C	-40° to +100°C
Stainless Steel & Aluminium	Stainless Steel	Stainless Steel	Stainless Steel
Black Electroless Nickel & Electroless Nickel	Black Electroless Nickel & Electroless Nickel	Black Electroless Nickel & Electroless Nickel	Black Electroless Nickel & Electroless Nickel
Solder & Straight PCB Tails	Crimp & Straight PCB Tails	Crimp & Straight PCB Tails	Crimp & Straight PCB Tails
Pogo Pins & Pads	Pogo Pins & Pads	Pogo Pins & Pads	Twist Pin & Sockets
Gold over Nickel	Gold over Nickel	Gold over Nickel	Gold over Nickel
7, 14 & 19 way	7, 14 & 19 way	7, 14 & 19 way	7, 14 & 19 way
24 - 32 AWG	24 - 32 AWG	24 - 32 AWG	24 - 32 AWG
Factory Fitted	Factory Fitted	Factory Fitted	Factory Fitted
2 Amps continuous, 3 Amps peak	2 Amps continuous, 3 Amps peak	2 Amps continuous, 3 Amps peak	3 Amps
15 mOhm	15 mOhm	15 mOhm	8 mOhm
50 Volts DC	50 Volts DC	50 Volts DC	50 Volts DC
500 Volts	500 Volts	500 Volts	500 Volts
5 Gohm min (1 Gohm after immersion)	5 Gohm min (1 Gohm after immersion)	5 Gohm min (1 Gohm after immersion)	5 Gohm min (1 Gohm after immersion)
2,500	10,000	10,000	2,500, (500 Push Pull)
5 clocking positions: N, A, B, C & D	5 clocking positions: N, A, B, C & D	5 clocking positions: N, A, B, C & D	5 clocking positions: N, A, B, C & D
Yes	Yes	Yes	Yes
IP67	IP67	IP67	IP68, > 20m
24	28	32	37

		Page		Page	
Nemesis – Accessories	EMI Caps How to Order	41	Cable for the Nemesis Connector Range	Specification	47
	Dust Caps How to Order	42		How to Define	48
	Receptacle Dust Cap	43	Contact Technology	Pogo Contact Technology	49
	Plug Dust Cap	43		Twist Pin Contact Technology	49
	Jam Nut Tools	44			
Nemesis Connector Range	Weight Data	45	Product Safety Information	51	
Cannon Break Away Connector Range	Weight Data	46			

Nemesis Quick Term NEM-QT



Overview

ITT Cannon's Quick Term connector utilises the features & benefits of the High Mating range and allows the termination of the plugs & receptacles in the workshop or the field.

To assemble the product the user needs only normal workshop tools however mounting fixtures for the front shells are available. Please see the following pages for the range of backshells, cable ties & heat shrink boots.

Specifications			
Contact Type	Plugs = pogo, receptacles = pogo pads	Coupling	Snap-on / Breakaway
Contacts	Solder bucket	Coding	5 clocking positions, N, A, B, C & D
Wire size	22 - 32 AWG	Coding identification	Individual colours with coloured dot on both parts, N = blue, A = red, B = green, C = grey & D = yellow
Contact rating	2 Amps (3A peak)		
Voltage rating	50 Vdc		
Insulation resistance	5 Gohm min (1 Gohm after immersion)	Boot	Designed for heat shrink boot or overmoulded
Dielectric Withstand Voltage	500 Volts	Sealing	IP67
Operating temperature	-55°C to +125°	Layouts	7, 14 & 19
Contact resistance	15 mOhm maximum	Shell to shell resistance	<20 mOhm
Vibration	20 g's in accordance with MIL-STD-1344 Method 2005, Condition IV	Blind mate	Yes
Shock	50 g's in accordance with MIL-STD-1344 Method 2004, Condition E	Snap-on / Breakaway Forces	30N
Durability	10,000 cycles	Materials	Shell assemblies – Stainless steel
Plating	RoHS compliant black electroless nickel or electroless nickel, 500 hour salt spray		Back shells – Brass
Receptacle mounting	Hexagonal or optional tamper proof nut		Insulators – High temperature engineering polymer
EMI shielding	50dB attenuation 100MHz to 1000MHz in terminated condition		Seals – Fluorosilicone rubber
			Contacts – Copper alloy with gold over nickel plating

Nemesis Quick Term

NEM-QT – How to Order

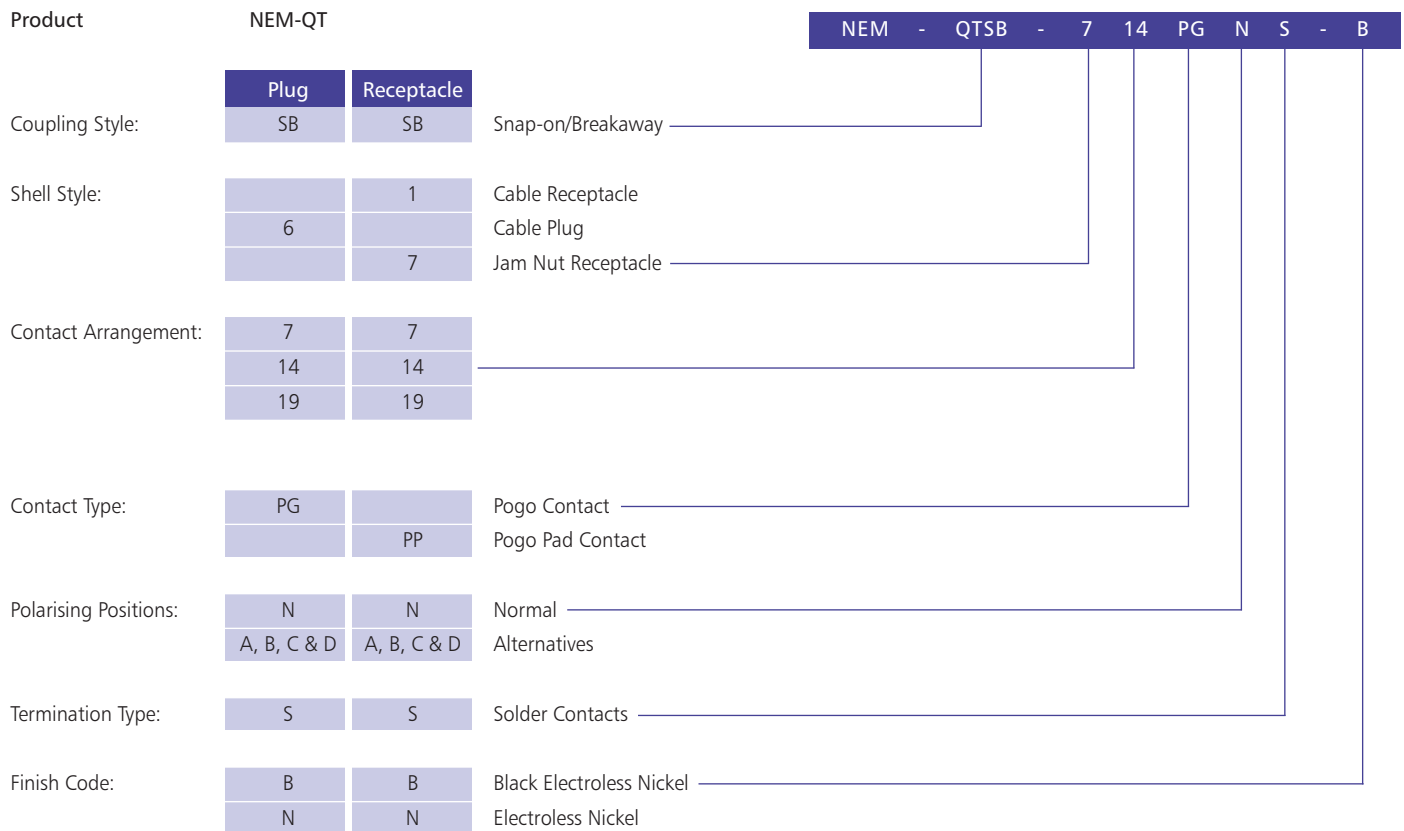

Quick Term is intermateable with High Mating and Super Clean

Nomenclature	Description	Part Numbers	Polarisation Suffix	
Cable Receptacle			Polarisation	Suffix
NEM-QTSB-17PPNS-B	7 Way QT Cable Receptacle	078413-6000	N	-6000
NEM-QTSB-114PPNS-B	14 Way QT Cable Receptacle	078414-6000	A	-6001
NEM-QTSB-119PPNS-B	19 Way QT Cable Receptacle	078415-6000	B	-6002
			C	-6003
			D	-6004
Cable Plug				
NEM-QTSB-67PGNS-B	7 Way QT Cable Plug	078377-6000		
NEM-QTSB-614PGNS-B	14 Way QT Cable Plug	078378-6000		
NEM-QTSB-619PGNS-B	19 Way QT Cable Plug	078379-6000		
Jam Nut Receptacle				
NEM-QTSB-77PPNS-B	7 Way QT Jam Nut Receptacle	078336-6000		
NEM-QTSB-714PPNS-B	14 Way QT Jam Nut Receptacle	078339-6000		
NEM-QTSB-719PPNS-B	19 Way QT Jam Nut Receptacle	078342-6000		

Nemesis Quick Term NEM-QT

Cable Receptacle Dimensions

Contact arrangement	Dimension A	Thread B
7	0.590 (15.00)	7/16-28 UNEF-2A
14	0.709 (18.00)	9/16-28 UN-2A
19	0.768 (19.50)	5/8-28 UN-2A

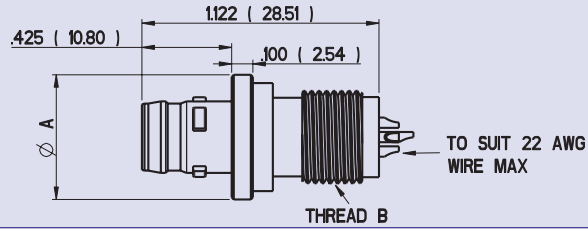

Cable Plug Dimensions

Contact arrangement	Dimension A	Thread B
7	0.590 (15.00)	7/16-28 UNEF-2A
14	0.699 (17.75)	9/16-28 UN-2A
19	0.748 (19.00)	5/8-28 UN-2A

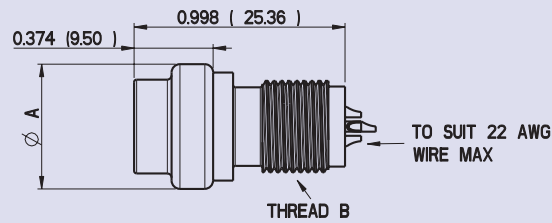

Jam Nut Receptacle Dimensions

Contact arrangement	Dimension A
7	0.591 (15.00)
14	0.709 (18.00)
19	0.768 (19.50)

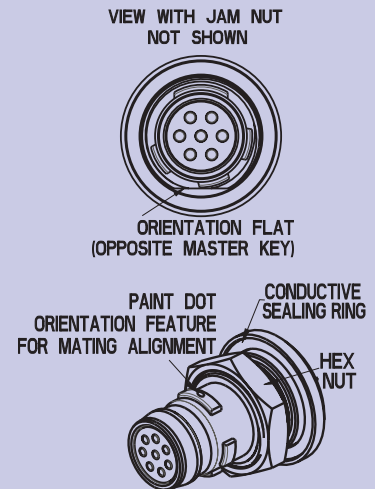
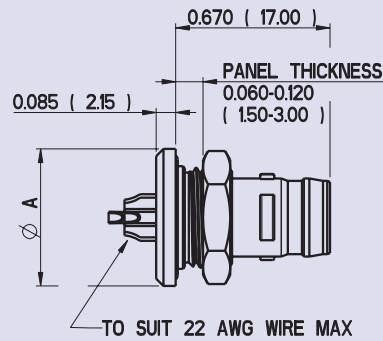
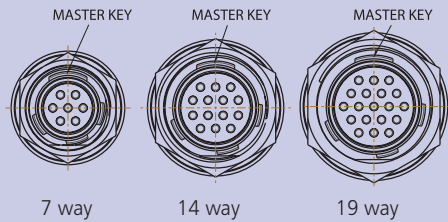

Jam Nut Receptacle Panel Cut-out

Contact arrangement	Dimension A	Dimension B
8	0.457 (11.60)	0.421 (10.70)
14	0.575 (14.60)	0.539 (13.70)
19	0.634 (16.10)	0.596 (15.15)

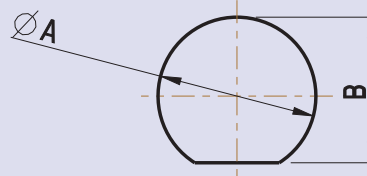

Color Coding

Polarisation letter	Color coding
N	Blue
A	Red
B	Green
C	Grey
D	Yellow

Contact Arrangements

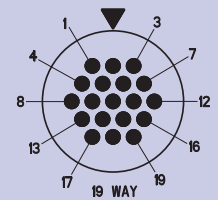
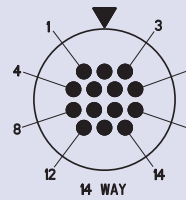
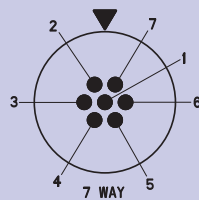

Face View, Pogo Pin Contacts. Cavity identification numbers are for reference only; they do not appear on connectors.

Nemesis Quick Term – High Speed NEM-QTHS



Overview

ITT Cannon's Quick Term High Speed connectors have been designed to allow users to create ruggedized interconnects for 10 Gigabit Ethernet and other High Speed protocols.

Based upon the QT range the QTHS uses the same backshells, cable ties and heat shrink boots and has been utilised in USB, HDMI and 10GBASE-T (CAT6) applications.

Specifications			
Contact Type	Plugs = pogo, receptacles = pogo pads	Coupling	Snap-on / Breakaway
Contacts	Solder bucket	Coding	5 clocking positions, N, A, B, C & D
Wire size	22 - 32 AWG	Coding identification	Individual colours with coloured dot on both parts, N = blue, A = red, B = green, C = grey & D = yellow
Contact rating	2 Amps (3A peak)		
Voltage rating	50 Vdc		
Insulation resistance	5 Gohm min (1 Gohm after immersion)	Boot	Designed for heat shrink boot or overmoulded
Dielectric Withstand Voltage	500 Volts	Sealing	IP67
Operating temperature	-55°C to +125°	Layouts	7, 14 & 19
Contact resistance	15 mOhm maximum	Shell to shell resistance	<20 mOhm
Vibration	20 g's in accordance with MIL-STD-1344 Method 2005, Condition IV	Blind mate	Yes
Shock	50 g's in accordance with MIL-STD-1344 Method 2004, Condition E	Snap-on / Breakaway Forces	30N
Durability	10,000 cycles	Materials	Shell assemblies – Stainless steel
Plating	RoHS compliant black electroless nickel or electroless nickel, 500 hour salt spray		Back shells – Brass
Receptacle mounting	Hexagonal or optional tamper proof nut		Insulators – High temperature engineering polymer
EMI shielding	50dB attenuation 100MHz to 1000MHz in terminated condition		Seals – Fluorosilicone rubber
			Contacts – Copper alloy with gold over nickel plating

Nemesis Quick Term – High Speed

NEM-QTHS – How to Order

Product	NEM-QTHS		NEM - QTHSSB - 7 14 PG N S - B
Coupling Style:	Plug SB	Receptacle SB	Snap-on/Breakaway
Shell Style:		1	Cable Receptacle
	6		Cable Plug
		7	Jam Nut Receptacle
Contact Arrangement:	8	8	8
	14	14	
	19	19	
Contact Type:	PG		Pogo Contact
		PP	Pogo Pad Contact
Polarising Positions:	N	N	Normal
	A, B, C & D	A, B, C & D	Alternatives
Termination Type:	S	S	Solder Contacts
		T	PCB Tails
Finish Code:	B	B	Black Electroless Nickel
	N	N	Electroless Nickel

Quick Term High Speed is not intermateable with High Mating and Super Clean

Nomenclature	Description	Part Numbers	Polarisation Suffix	
Cable Receptacle			Polarisation	Suffix
NEM-QTHSSB-18PPNS-B	8 Way QTHS Cable Receptacle	078416-7000	N	-7000
NEM-QTHSSB-114PPNS-B	14 Way QTHS Cable Receptacle	078414-7000	A	-7001
NEM-QTHSSB-119PPNS-B	19 Way QTHS Cable Receptacle	078415-7000	B	-7002
			C	-7003
			D	-7004
Cable Plug				
NEM-QTHSSB-68PGNS-B	8 Way QTHS Cable Plug	078380-7000		
NEM-QTHSSB-614PGNS-B	14 Way QTHS Cable Plug	078378-7000		
NEM-QTHSSB-619PGNS-B	19 Way QTHS Cable Plug	078379-7000		
Jam Nut Receptacle				
NEM-QTHSSB-78PPNS-B	8 Way QTHS Jam Nut Receptacle Solder Contacts	078381-7000		
NEM-QTHSSB-714PPNS-B	14 Way QTHS Jam Nut Receptacle Solder Contacts	078339-7000		
NEM-QTHSSB-719PPNS-B	19 Way QTHS Jam Nut Receptacle Solder Contacts	078342-7000		
NEM-QTHSSB-78PPNT-B	8 Way QTHS Jam Nut Receptacle PCB Tail	078381-8000	Polarisation	Suffix
NEM-QTHSSB-714PPNT-B	14 Way QTHS Jam Nut Receptacle PCB Tail	078339-8000	N	-8000
NEM-QTHSSB-719PPNT-B	19 Way QTHS Jam Nut Receptacle PCB Tail	078342-8000	A	-8001
			B	-8002
			C	-8003
			D	-8004

Nemesis Quick Term – High Speed NEM-QTHS



Cable Receptacle Dimensions

Contact arrangement	Dimension A	Thread B
8	0.590 (15.00)	7/16-28 UNEF-2A
14	0.709 (18.00)	9/16-28 UN-2A
19	0.768 (19.50)	5/8-28 UN-2A

Cable Plug Dimensions

Contact arrangement	Dimension A	Thread B
8	0.590 (15.00)	7/16-28 UNEF-2A
14	0.699 (17.75)	9/16-28 UN-2A
19	0.748 (19.00)	5/8-28 UN-2A

Jam Nut Receptacle Dimensions Solder Contacts

Contact arrangement	Dimension A
7	0.591 (15.00)
14	0.709 (18.00)
19	0.768 (19.50)

8 way MASTER KEY

14 way MASTER KEY

19 way MASTER KEY

Nemesis Quick Term – High Speed NEM-QTHS

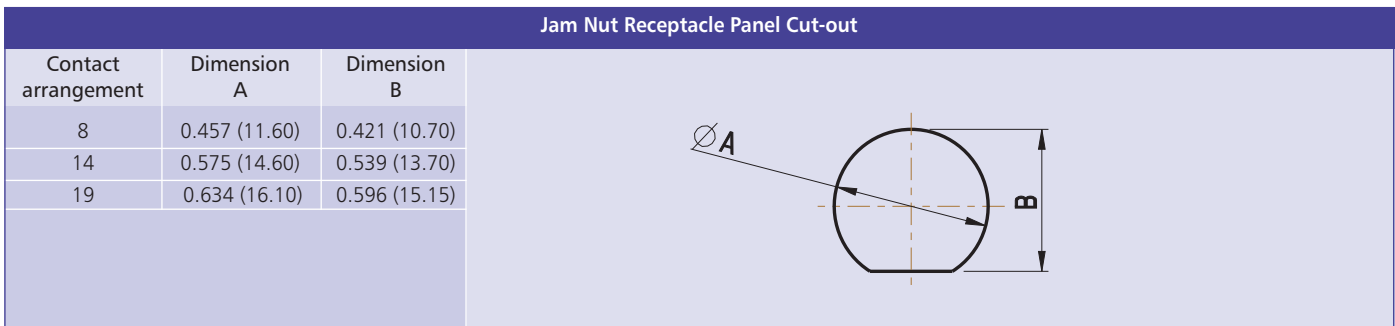
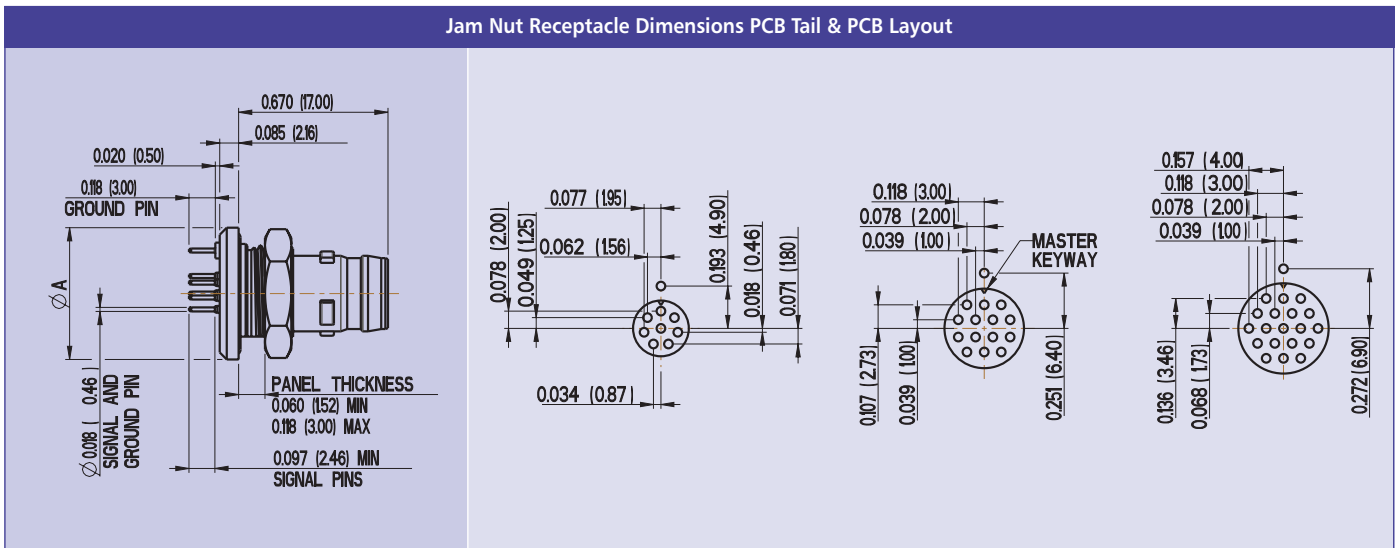

Color Coding	
Polarisation letter	Color coding
N	Blue
A	Red
B	Green
C	Grey
D	Yellow

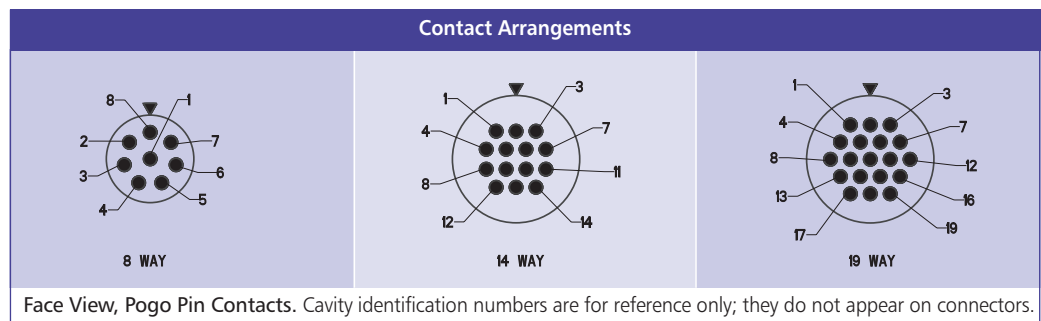

Nemesis Quick Term – Backshells

NEM-QTBS – How to Order



Product: NEM-BS

Contact Arrangement: 7 / 8, 14, 19

Shell Size: 1, 2, 3, 4, 5, 6, 7, 8, 9

Finish Code: N Electroless Nickel

NEM - BS - 14 5 - N



Nomenclature	Description	Part Numbers
Quick Term Backshells		
NEM-BS-71-N	7 / 8 Way Backshell size 1	448-7873-001
NEM-BS-72-N	7 / 8 Way Backshell size 2	448-7873-002
NEM-BS-73-N	7 / 8 Way Backshell size 3	448-7873-003
NEM-BS-144-N	14 Way Backshell size 4	448-7873-004
NEM-BS-145-N	14 Way Backshell size 5	448-7873-005
NEM-BS-146-N	14 Way Backshell size 6	448-7873-006
NEM-BS-197-N	19 Way Backshell size 7	448-7873-007
NEM-BS-198-N	19 Way Backshell size 8	448-7873-008
NEM-BS-199-N	19 Way Backshell size 9	448-7873-009

Backshell				
Contact arrangement	Dimension A	Dimension B	Dimension C	Thread D
7 / 8	0.528 (13.40)	0.236 (6.00)	0.299 (7.60)	7/16-28 UNEF-2B
7 / 8	0.528 (13.40)	0.264 (6.70)	0.327 (8.30)	7/16-28 UNEF-2B
7 / 8	0.528 (13.40)	0.291 (7.40)	0.354 (9.00)	7/16-28 UNEF-2B
14	0.652 (16.55)	0.315 (8.00)	0.378 (9.60)	9/16-28 UN-2B
14	0.652 (16.55)	0.354 (9.00)	0.417 (10.60)	9/16-28 UN-2B
14	0.652 (16.55)	0.394 (10.00)	0.457 (11.60)	9/16-28 UN-2B
19	0.717 (18.20)	0.364 (9.25)	0.427 (10.85)	5/8-28 UN-2B
19	0.717 (18.20)	0.404 (10.25)	0.467 (11.85)	5/8-28 UN-2B
19	0.717 (18.20)	0.443 (11.25)	0.506 (12.85)	5/8-28 UN-2B

Nemesis Quick Term – Heat Shrink Boots, Cable Ties & Tools

Heat Shrink Boot Dimensions			
Part number	Contact arrangement	Dimension A	Dimension B
252-7689-000	7 / 8 way	2.16 (55)	0.63 (16)
252-7689-001	14 / 19 way	2.16 (55)	0.94 (24)

Heat Shrink Boot Temperature Range = -55°C to +85°C, Heat Shrink Boot Shrink Rate = 4 : 1

Description	Number of ways	Part Numbers
Band-it Cable Tie	7, 8, 14 & 19	317-7998-734
Band-it Tool	7, 8, 14 & 19	T4924
QT/QTHS Cable Plug Support Tool	7 & 8	T4918
QT/QTHS Cable Plug Support Tool	14	T4919
QT/QTHS Cable Plug Support Tool	19	T4920
QT/QTHS Cable Receptacle Support Tool	7 & 8	T4921
QT/QTHS Cable Receptacle Support Tool	14	T4922
QT/QTHS Cable Receptacle Support Tool	19	T4923

Cable Tie

Cable Tie Tool

Support Tool Material: Silver Steel

QT/QTHS Cable Receptacle Support Tool Dimensions				
Contact arrangement	Dimension A	Dimension B	Dimension C	Dimension D
7 / 8	1.364 (34.65)	0.577 (14.65)	0.445 (11.30)	0.295 (7.50)
14	1.364 (34.65)	0.577 (14.65)	0.553 (14.05)	0.295 (7.50)
19	1.364 (34.65)	0.577 (14.65)	0.630 (16.00)	0.295 (7.50)

QT/QTHS Cable Plug Support Tool Dimensions				
Contact arrangement	Dimension A	Dimension B	Dimension C	Dimension D
7 / 8	1.362 (34.60)	0.575 (14.60)	0.492 (12.50)	0.295 (7.50)
14	1.362 (34.60)	0.575 (14.60)	0.610 (15.50)	0.295 (7.50)
19	1.362 (34.60)	0.575 (14.60)	0.650 (16.50)	0.295 (7.50)

Nemesis Quick Term – Assembly instructions

Front shell assembly Backshell Band-it Heat shrink boot

Tooling required :-
 1) Band-it tool - tie-dex 2
 2) Front shell support tool :-
 T4918 - 7 way plug T4921 - 7 way receptacle
 T4919 - 14 way plug T4922 - 14 way receptacle
 T4920 - 19 way plug T4923 - 19 way receptacle

1

20MM TRIM JACKET BACKSHELL SHRINK SLEEVE BOOT CABLE

Slide boot and backshell onto cable (these can be put on later if building a pigtail assembly). Trim outer jacket back to dimension shown, exposing braid, being careful not to nick or damage it.

2

2.00 BRAID (FOLD BACK)

Fold the braid back over the jacket, this can be taped back in position whilst carrying out the wire termination. Trim back the wire insulation to the dimension shown, if a stranded center conductor, ensure the twist is tight and tin dip the wire ends in preparation for soldering to contacts.

3

FRONT SHELL ASSEMBLY

Fit the appropriate support tool to a vice and plug on front shell assembly. Offer up the wires, one at a time, to the required contact and solder to position.

4

BACKSHELL BAND IT

TRIM BRAID FLUSH TO BAND IT EDGE

Slide the backshell over the wires and screw onto the front shell to a torque of 30 / 35 lb.ins. (3.40 / 3.95 nm). Flare the braid over the tube of the backshell. If the cable has a strain relief, this should be wrapped and secured under the Band-it. Load the Band-it to the tool, note - the Band-it should be wrapped twice, locate the Band-it over the braid (there is a u/cut on the tube to indicate the position of the Band-it) and operate the tool to secure the Band-it around the braid. Trim the braid and strain relief (if fitted) approx. flush with the edge of the Band-it.

5

HEAT SHRINK BOOT

BOOT SHOULD FULLY COVER THE BACKSHELL

Slide the boot fully over the backshell and apply heat to shrink in position.

Cannon Break Away



Overview

ITT Cannon's Break Away connector series offers a wide range of layouts in a highly engineered ruggedised design for harsh environments. The range shell options include banding

platforms and threaded allowing backshell accessories to be fitted whilst the shell material options are aluminium or stainless steel.

Specifications			
Contact Type	Pogo pins and pads	Plating	Black Zinc Nickel, Electroless Nickel and Teflon
Contacts	Solder bucket & PC Tail	EMI shielding	40dB attenuation 100MHz to 1000MHz
Wire size	# 22 - # 28 AWG	Coupling	Snap-on / Breakaway (Quick Disconnect)
Contact rating	2 Amps (3A peak)	Coding	4 clocking positions, A, B, C & D
Voltage rating	500 VAC RMS Sea Level	Sealing	IP67
Insulation resistance	5,000 Mohm minimum	Layouts	3, 4, 7, 10, 19 & 37
Dielectric Withstand Voltage	750 Volts AC	Blind mate	Yes
Operating temperature	-55°C to +150°C	Snap-on / Breakaway Forces	30N
Contact resistance	15 mOhm maximum	Materials	Shells – Aluminium Alloy or Stainless Steel Insulators – Thermoplastic Seals – Fluorosilicone Contacts – Copper Alloy with Gold over Nickel Plating
Vibration	20 g's in accordance with MIL-STD-1344 Method 2005, Condition IV		
Shock	50 g's in accordance with MIL-STD-1344 Method 2004, Condition E		
Durability	10,000 cycles		

Cannon Break Away How to Order



Product	CBA		CBA - A - 1 - F - 5-3 - PGS - A
Class:	A	Environmental Plug or Receptacle with Banding/Overmolding Platform	
	B	Environmental Plug or Receptacle with Threaded Accessory Attachment	
	C	Back- Potted Plug	
Shell Style:	1	In-Line Receptacle	
	6	Straight Plug	
	9	Jam Nut Plug	
Material/Plating:	F	Aluminum/Electroless Nickel	
	T	Aluminium/Teflon Nickel	
	Y	Stainless Steel/Zinc Nickel, Black	
	Z	Aluminum/Zinc Nickel, Black	
Shell size/ Contact Arrangement:	5-3	3 Size 23 Contacts	
	6-4	4 Size 23 Contacts	
	6-7	7 Size 23 Contacts	
	7-10	10 Size 23 Contacts	
	9-19	19 Size 23 Contacts	
	12-37	37 Size 23 Contacts	
Contact Style:	PGS	Pin, Pogo solder bucket	
	PPS	Pad, Pogo solder bucket	
	PGT	Pin, Pogo PC tail	
	PPT	Pad, Pogo PC tail	
Shell Clocking (Position):	A	Normal 150° 210°	
	B	Clocking Position B 75° 210°	
	C	Clocking Position C 95° 230°	
	D	Clocking Position D 140° 275°	

Ordering Examples			
Nomenclature	Description (aluminium shell with black zinc nickel plating)	Part Numbers	Part Number Suffix's
In-Line Receptacle			Class/Shell Style Suffix
CBA-B1Z-53PGS-A	3 way in-line receptacle w thread , pogo pins, solder bucket, A clocking	156500-2300	A1 -0xxx
CBA-B1Z-64PGS-A	4 way in-line receptacle w thread, pogo pins, solder bucket, A clocking	156501-2300	A6 -1xxx
CBA-B1Z-67PGS-A	7 way in-line receptacle w thread, pogo pins, solder bucket, A clocking	156502-2300	B1 -2xxx
CBA-B1Z-710PGS-A	10 way in-line receptacle w thread, pogo pins, solder bucket, A clocking	156503-2300	B6 -3xxx
CBA-B1Z-919PGS-A	19 way in-line receptacle w thread, pogo pins, solder bucket, A clocking	156504-2300	C9 -4xxx
CBA-B1Z-1237PGS-A	37 way in-line receptacle w thread, pogo pins, solder bucket, A clocking	156505-2300	
			Material/Plating Suffix
Straight Plug			F -x0xx
CBA-B6Z-53PPS-A	3 way straight plug w thread , pogo pads, solder bucket, A clocking	156500-3310	T -x1xx
CBA-B6Z-64PPS-A	4 way straight plug w thread , pogo pads, solder bucket, A clocking	156501-3310	Y -x2xx
CBA-B6Z-67PPS-A	7 way straight plug w thread , pogo pads, solder bucket, A clocking	156502-3310	Z -x3xx
CBA-B6Z-710PPS-A	10 way straight plug w thread , pogo pads, solder bucket, A clocking	156503-3310	
CBA-B6Z-919PPS-A	19 way straight plug w thread , pogo pads, solder bucket, A clocking	156504-3310	Contact Style Suffix
CBA-B6Z-1237PPS-A	37 way straight plug w thread , pogo pads, solder bucket, A clocking	156505-3310	PGS -xx0x
			PPS -xx1x
			PGT -xx2x
			PPT -xx3x
Jam Nut Plug			Clocking Suffix
CBA-C9Z-53PPT-A	3 way jam nut plug, pogo pads, PC tails, A clocking	156500-4330	A -xxx0
CBA-C9Z-64PPT-A	4 way jam nut plug, pogo pads, PC tails, A clocking	156501-4330	B -xxx1
CBA-C9Z-67PPT-A	7 way jam nut plug, pogo pads, PC tails, A clocking	156502-4330	C -xxx2
CBA-C9Z-710PPT-A	10 way jam nut plug, pogo pads, PC tails, A clocking	156503-4330	D -xxx3
CBA-C9Z-919PPT-A	19 way jam nut plug, pogo pads, PC tails, A clocking	156504-4330	
CBA-C9Z-1237PPT-A	37 way jam nut plug, pogo pads, PC tails, A clocking	156505-4330	

Cannon Break Away

In-Line Receptacle Dimensions

Layout	ØA	ØB	B, Thread UNEF-2A
5 - 3	0.450 (11.43)	0.246 (6.25)	0.2500-32
6 - 4	0.520 (13.21)	0.290 (7.37)	0.3125-32
6 - 7	0.520 (13.21)	0.290 (7.37)	0.3125-32
7 - 10	0.580 (14.73)	0.390 (9.91)	0.4375-28
9 - 19	0.695 (17.65)	0.500 (12.70)	0.5625-24
12 - 37	0.880 (22.35)	0.650 (16.51)	0.6875-24

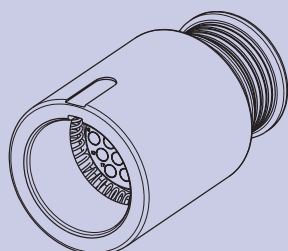
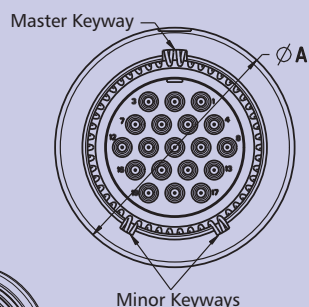

Pogo Pad Receptacle

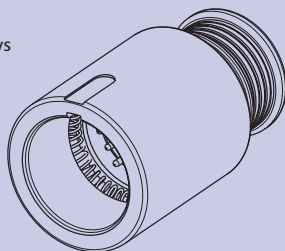

Pogo Pin Receptacle

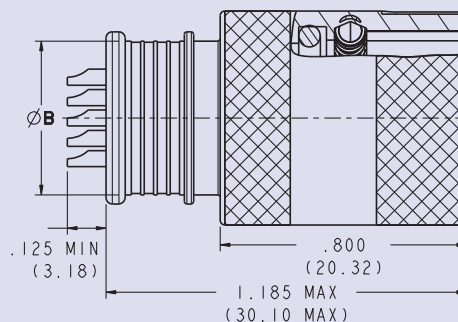

Banding Platform

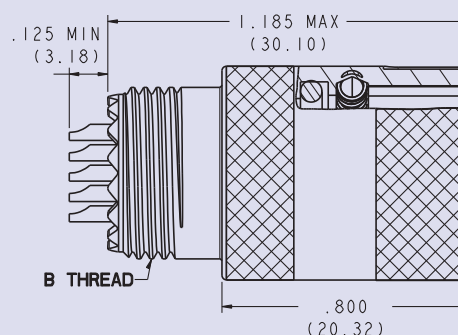

Threaded Accessory

Straight Plug Dimensions

Layout	ØA	ØB	ØC	C, Thread UNEF-2A
5 - 3	0.422 (10.72)	0.248 (6.30)	0.246 (6.25)	0.2500-32
6 - 4	0.485 (12.32)	0.311 (7.90)	0.290 (7.37)	0.3125-32
6 - 7	0.485 (12.32)	0.311 (7.90)	0.290 (7.37)	0.3125-32
7 - 10	0.565 (14.35)	0.381 (9.68)	0.390 (9.91)	0.4375-28
9 - 19	0.660 (16.76)	0.481 (12.22)	0.500 (12.70)	0.5625-24
12 - 37	0.851 (21.62)	0.676 (17.17)	0.650 (16.51)	0.6875-24

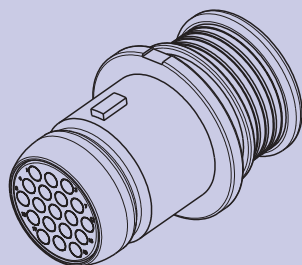
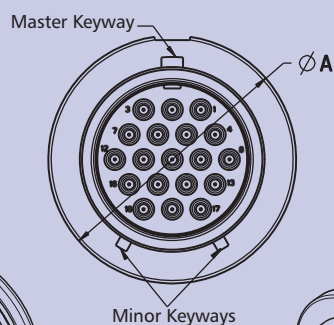

Pogo Pad Plug

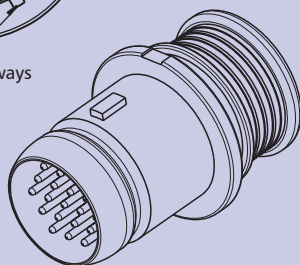

Pogo Pin Plug

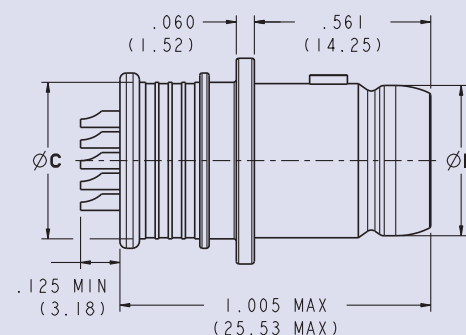

Banding Platform

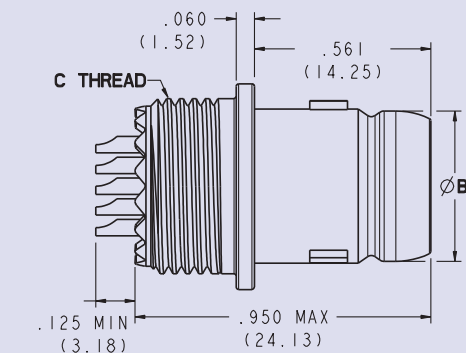

Threaded Accessory

Jam Nut Plug Dimensions							
Layout	ØA	ØB	ØC	D, Flat	Thread, E	F	ØH
5-3	0.790 (20.07)	0.5740 (14.58)	0.248 (6.30)	0.415 (10.54)	.4375-28 UNEF-2A	0.109 (2.77)	0.244 (6.20)
6-4	0.830 (21.08)	0.6250 (15.88)	0.311 (7.90)	0.467 (11.86)	.5000-32 UN-2A	0.109 (2.77)	0.330 (8.38)
6-7	0.830 (21.08)	0.6250 (15.88)	0.311 (7.90)	0.467 (11.86)	.5000-32 UN-2A	0.109 (2.77)	0.330 (8.38)
7-10	0.910 (23.11)	0.7620 (19.35)	0.381 (9.68)	0.594 (15.09)	.6250-28 UN-2A	0.109 (2.77)	0.432 (10.97)
9-19	1.000 (25.40)	0.8140 (20.68)	0.481 (12.22)	0.655 (16.64)	.6875-28 UN-2A	0.109 (2.77)	0.551 (14.00)
12-37	1.180 (29.97)	1.0060 (25.55)	0.676 (17.17)	0.843 (21.41)	.8750-28 UN-2A	0.109 (2.77)	0.703 (17.86)

Jam Nut Plug Panel Cut-out		
Layout	ØA	B, Flat
5-3	0.448 (11.38)	0.423 (10.74)
6-4	0.510 (12.95)	0.475 (12.07)
6-7	0.510 (12.95)	0.475 (12.07)
7-10	0.635 (16.13)	0.602 (15.29)
9-19	0.698 (17.73)	0.663 (16.84)
12-37	0.885 (22.48)	0.851 (21.62)

Cannon Break Away

Dimensions PCB Layout

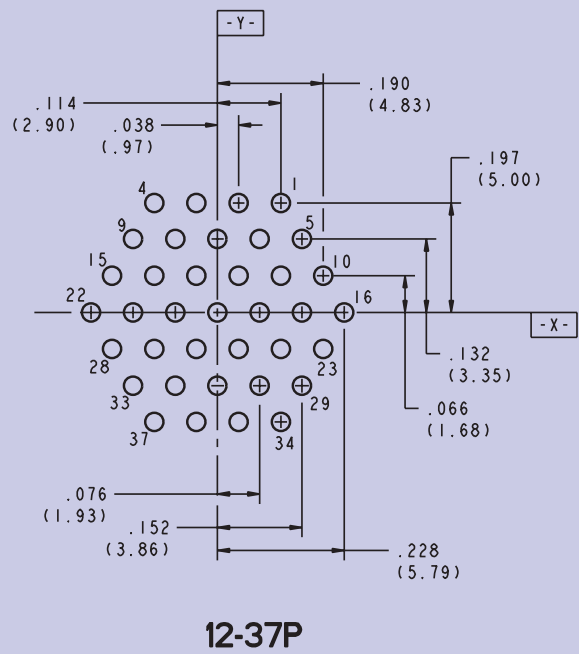
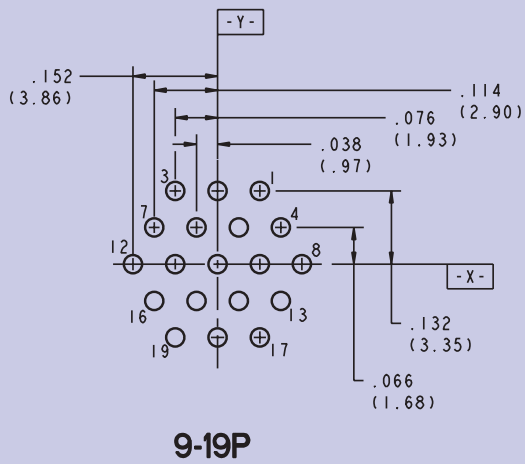
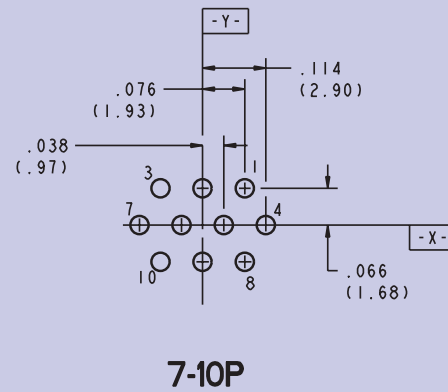
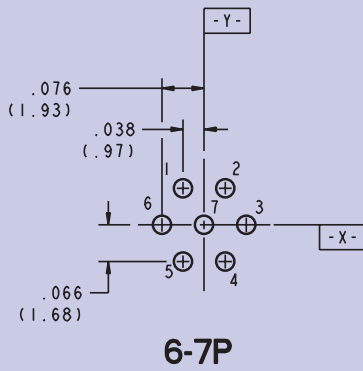
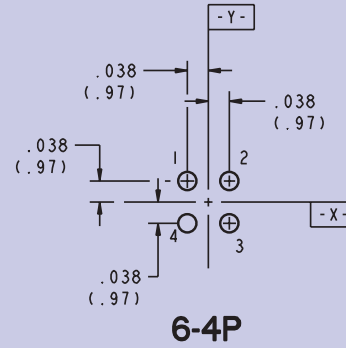
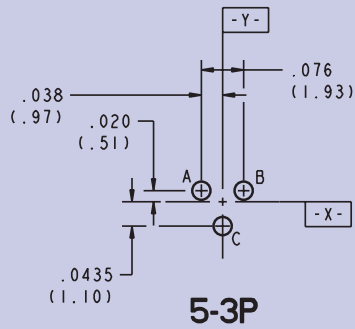

Face View, Pogo Pin Contact Arrangements

Contact Arrangements

Plug Layouts

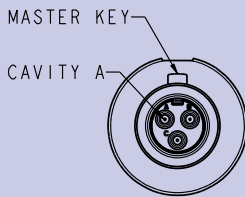

5-3 LAYOUT

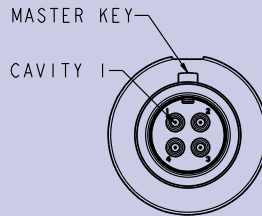

6-4 LAYOUT

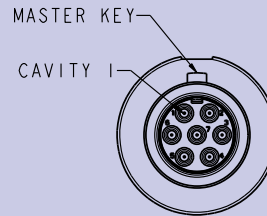

6-7 LAYOUT

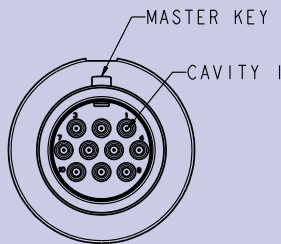

7-10 LAYOUT

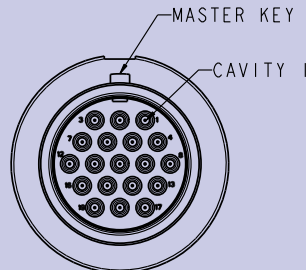

9-19 LAYOUT

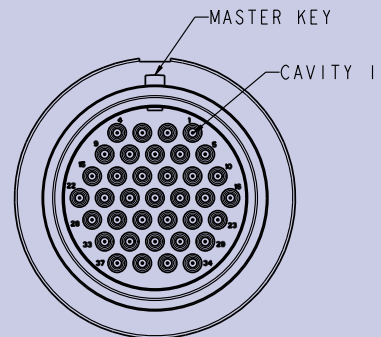

12-37 LAYOUT

Receptacle Layouts

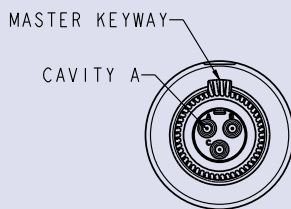

5-3 LAYOUT

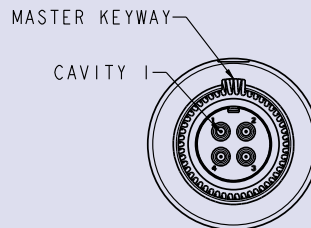

6-4 LAYOUT

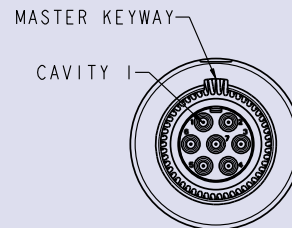

6-7 LAYOUT

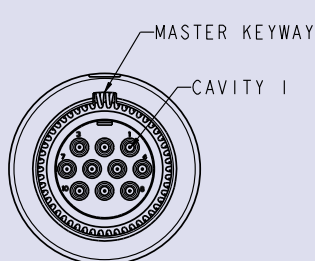

7-10 LAYOUT

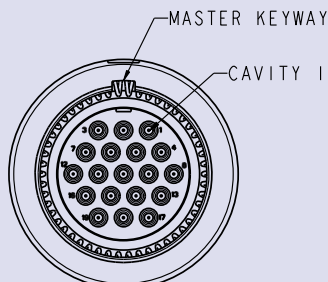

9-19 LAYOUT

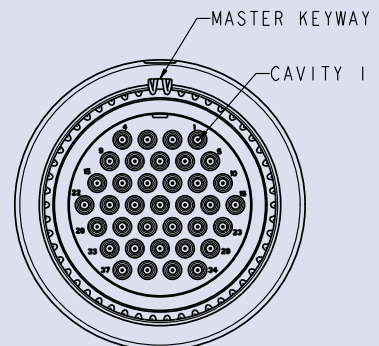

12-37 LAYOUT

Face View, Pogo Pin Contact Arrangements

Cannon Break Away – Backshells

How to Order

Product	CBA BACKSHELL		CBA-B - A - S - F - 1 - 00 - 0			
Class:	A	Environmental				
Shell Style:	S	Straight				
	A	45 Deg Angle				
	R	90 Deg Angle				
Material/Plating:	F	Aluminum/Electroless Nickel				
	Z	Aluminum/Zinc Nickel, Black				
	T	Aluminium/Teflon Nickel				
		Shell Size				
Accessory	1	0.2500-32 UNEF-2B	5			
Thread Size:	2	0.3125-32 UNEF-2B	6			
	4	0.4375-28 UNEF-2B	7			
	6	0.5625-24 UNEF-2B	9			
	8	0.6875-24 UNEF-2B	12			
Length:	00	No Length for Angled Versions				
	03	0.75 inch				
	06	1.50 inch				
	08	2.00 inch				
Cable Entry Diameter:	0	0.250 inch				
	1	0.312 inch				
	2	0.375 inch				
	3	0.438 inch				
	4	0.500 inch				

Ordering Examples			
Nomenclature	Description (aluminium shell with black zinc nickel plating)	Part Numbers	Part Number Prefix /Suffix's
Straight Backshell			
CBA-BA-SZ-103-0	Size 1 Straight Backshell for Size 5 Connector, 0.75 inch length, size 0 cable entry	157200-2010	Class/Shell Style Prefix AS 15720x-xxxx
CBA-BA-SZ-203-1	Size 2 Straight Backshell for Size 6 Connector, 0.75 inch length, size 1 cable entry	157200-2021	AA 157210-xxxx
CBA-BA-SZ-303-2	Size 4 Straight Backshell for Size 7 Connector, 0.75 inch length, size 2 cable entry	157200-2042	AR 157220-xxxx
CBA-BA-SZ-403-3	Size 6 Straight Backshell for Size 9 Connector, 0.75 inch length, size 3 cable entry	157200-2063	
CBA-BA-SZ-503-4	Size 8 Straight Backshell for Size 12 Connector, 0.75 inch length, size 4 cable entry	157200-2084	Material/Plating Suffix F xxxxxx-0xxx Z xxxxxx-2xxx T xxxxxx-3xxx
45° Backshell			
CBA-BA-AZ-100-0	Size 1 45° Backshell for Size 5 Connector, no length, size 0 cable entry	157210-2010	
CBA-BA-AZ-200-1	Size 2 45° Backshell for Size 6 Connector, no length, size 1 cable entry	157210-2021	Accessory Thread Size Suffix
CBA-BA-AZ-300-2	Size 4 45° Backshell for Size 7 Connector, no length, size 2 cable entry	157210-2042	1 xxxxxx-x01x
CBA-BA-AZ-400-3	Size 6 45° Backshell for Size 9 Connector, no length, size 3 cable entry	157210-2063	2 xxxxxx-x02x
CBA-BA-AZ-500-4	Size 8 45° Backshell for Size 12 Connector, no length, size 4 cable entry	157210-2084	4 xxxxxx-x04x 6 xxxxxx-x06x 8 xxxxxx-x08x
90° Backshell			
CBA-BA-RZ-100-0	Size 1 90° Backshell for Size 5 Connector, no length, size 0 cable entry	157220-2010	Length Prefix (AS Shell Style Only)
CBA-BA-RZ-200-1	Size 2 90° Backshell for Size 6 Connector, no length, size 1 cable entry	157220-2021	03 157200-xxxx
CBA-BA-RZ-300-2	Size 4 90° Backshell for Size 7 Connector, no length, size 2 cable entry	157220-2042	06 157203-xxxx
CBA-BA-RZ-400-3	Size 6 90° Backshell for Size 9 Connector, no length, size 3 cable entry	157220-2063	08 157205-xxxx
CBA-BA-RZ-500-4	Size 8 90° Backshell for Size 12 Connector, no length, size 4 cable entry	157220-2084	Cable Entry Diameter Suffix 0 xxxxxx-xxx0 1 xxxxxx-xxx1 2 xxxxxx-xxx2 3 xxxxxx-xxx3 4 xxxxxx-xxx4

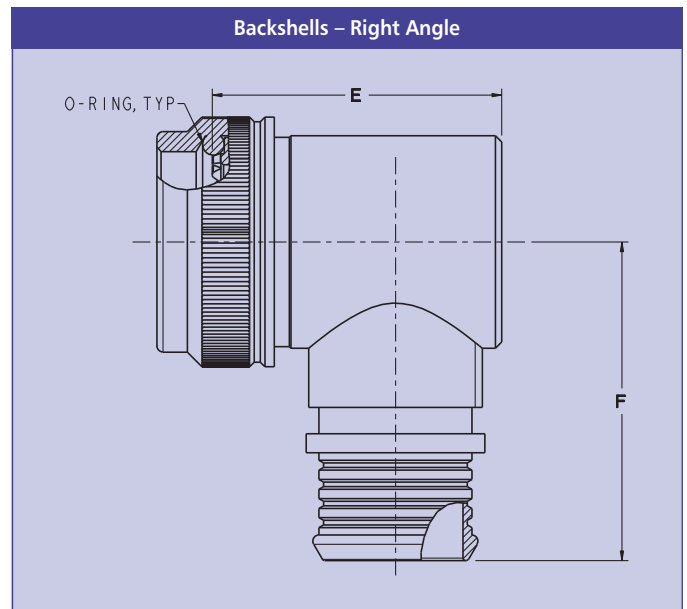
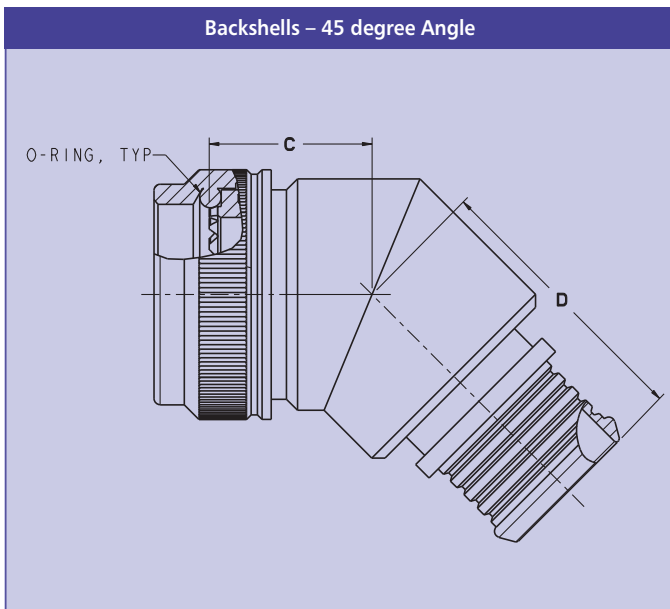
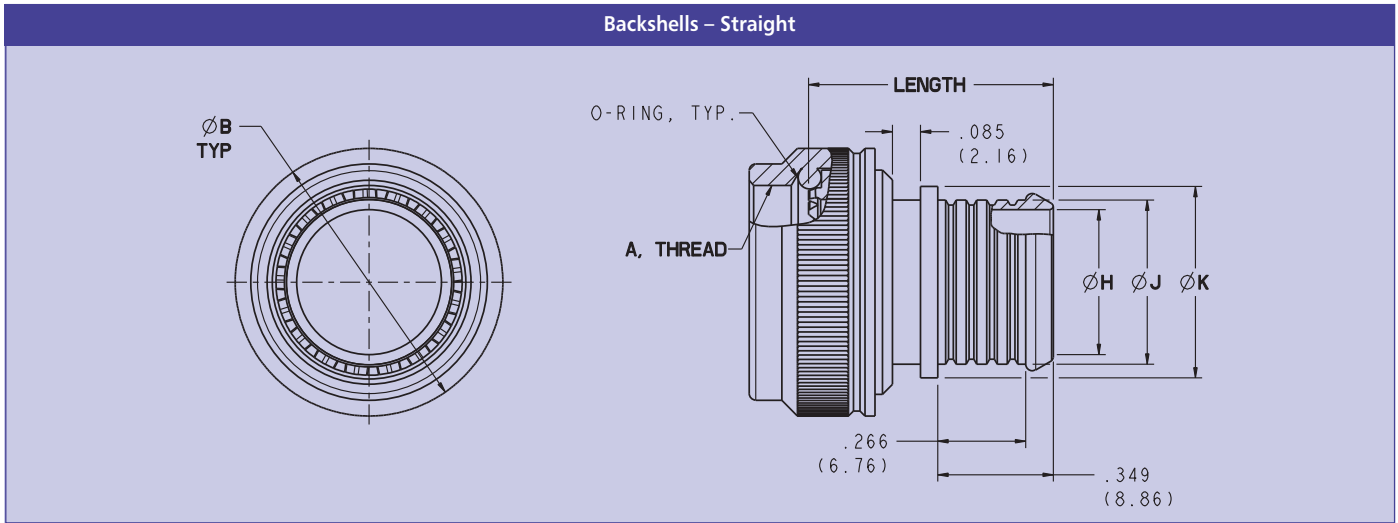

Backshell Dimensions								
Shell Size Code	Shell Size/Contact Arrangement	A, Thread	ØB (MAX)	C, MAX	D, MAX	E, MAX	F, MAX	Cable Entry Size Code Options
1	5-3	0.2500-32 UNEF-2B	0.470 (11.94)	0.542 (13.77)	0.875 (22.23)	0.875 (22.23)	1.000 (25.40)	0
2	6-4	0.3125-32 UNEF-2B	0.577 (14.66)	0.542 (13.77)	0.917 (23.29)	0.875 (22.23)	1.000 (25.40)	1
3	6-7	0.3125-32 UNEF-2B	0.577 (14.66)	0.542 (13.77)	0.917 (23.29)	0.875 (22.23)	1.000 (25.40)	1
4	7-10	0.4375-28 UNEF-2B	0.637 (16.18)	0.570 (14.48)	0.929 (23.60)	0.875 (22.23)	1.062 (26.97)	2
5	9-19	0.5625-24 UNEF-2B	0.758 (19.25)	0.590 (14.99)	0.955 (24.26)	1.000 (25.40)	1.125 (28.58)	3
6	12-37	0.6875-24 UNEF-2B	0.896 (22.76)	0.640 (16.26)	0.994 (25.25)	1.125 (28.58)	1.187 (30.15)	4

Cable Entry Dimensions - All Styles			
Size Code	ØH	ØJ	ØK
0	0.250 (6.35)	0.308 (7.82)	0.391 (9.93)
1	0.312 (7.92)	0.370 (9.40)	0.453 (11.51)
2	0.375 (9.53)	0.433 (11.00)	0.516 (13.11)
3	0.438 (11.13)	0.496 (12.60)	0.579 (14.71)
4	0.500 (12.70)	0.558 (14.17)	0.641 (16.28)
5	0.562 (14.27)	0.620 (15.75)	0.703 (17.86)
6	0.625 (15.88)	0.683 (17.35)	0.766 (19.46)

Nemesis Space Saver NEM-SS



Overview

ITT's Space Saver Connector takes interconnects to an industry leading lowest possible profile for ruggedized wearable equipment.

The connector features pogo pin technology utilizing ITT's unique spring probe pin/pad contact system for a durable and long life connection.

Patent Pending

Specifications			
Contact Type	Cable Plug = solder, jam nut receptacle = PC tails	Coding Identification	Individual colors with colored dot on both parts plus indication on the boot; N=blue, A=red, B=green, C=grey and D=yellow
Contacts	Plug= pogo pads, receptacle = pogo pins	Boot	Cable dependant, either overmoulded or adhered
Wire Size	24 - 32 AWG		
Contact Rating	2 Amps continuous, 3 Amps peak	Sealing	IP67
Voltage Rating	50 Vdc	Layouts	7, 14 & 19
Insulation Resistance	5 Gohm min (1 Gohm after immersion)	Shell to Shell Resistance	<20 mOhm
Dielectric Withstand Voltage	500 Volts	Blind Mate	No
Operating Temperature	-55°C to +125°C	Cable	ITT standard or customer specified
Contact Resistance	15 mOhm maximum	Cable Earth Termination	360° cable braid termination to the shell
Vibration	In accordance with MIL STD 810G min integrity exposure & US Highway	Snap-on/Breakaway Forces	70-105N/13-23N dependent upon layout. Disconnect force applied 25.4 mm from center
Shock	Tested to 65g 6ms ½ sine wave pulse	Strain Relief	Designed to withstand a 10Kg pull off force minimum
Durability	2,500 cycles	Materials	Insulators – High temperature engineering polymer Seals - Fluorosilicone rubber Contacts - Copper alloy with gold over nickel plating Receptacle Shell = Aluminium Plug Shell = Stainless Steel
Plating	RoHS compliant 500 hour salt spray resistant black electroless nickel or electroless nickel		
Receptacle Mounting**	Tamper proof jam nut		
Receptacle Sealing	Using a conductive 'O' ring, non-conductive 'O' rings are available		
EMI Shielding	50db attenuation 100Mhz to 1000Mhz in terminated condition		
Coupling	Snap-on/Rip-away		
Coding	5 polarizing positions; N, A, B, C, and D		

Nemesis Space Saver NEM-SS – How to Order



Product	NEM-SS		NEM - SSSR - 7 14 PG N T - XXX B							
	Plug	Receptacle								
Coupling Style:	SR	SR	Snap-on/Rip-away							
Shell Style:	6		Cable Plug							
		7	Jam Nut Receptacle**							
Contact Arrangement:	7	7								
	14	14								
	19	19								
Contact Type:	PP		Pogo Pad Contact							
		PG	Pogo Contact							
Polarising Positions:	N	N	Normal							
	A, B, C & D	A, B, C & D	Alternatives							
Termination Type:	S		Solder Contacts							
		T	Straight PCB Tails							
		L	Straight PCB Tails with Location Pegs							
Termination Code:	XXX	XXX	See Cable for the Nemesis Connector Range on page 48							
Finish Code:	B	B	Black Electroless Nickel							
	N	N	Electroless Nickel							

** Requires special tool, see Jam Nut Tools on page 44

Nomenclature	Description	Part Numbers	Cable Length Part Number Suffixes			
Cable Plug			Polarisation/Length of Cable	Suffix	Polarisation/Length of Cable	Suffix
NEM-SSSR-67PPNS-001B	7 Way SS Cable Plug w 1m cable	078360-0010	N 1m	-0010	C 3m	-0023
NEM-SSSR-614PPNS-004B	14 Way SS Cable Plug w 1m cable	078362-0010	A 1m	-0011	D 3m	-0024
NEM-SSSR-619PPNS-007B	19 Way SS Cable Plug w 1m cable	078364-0010	B 1m	-0012	N 5m	-0030
			C 1m	-0013	A 5m	-0031
			D 1m	-0014	B 5m	-0032
			N 3m	-0020	C 5m	-0033
			A 3m	-0021	D 5m	-0034
			B 3m	-0022		
Jam Nut Receptacle			Polarisation	Suffix	Polarisation	Suffix
NEM-SSSR-77PGNT-B	7 Way SS Jam Nut Receptacle	078359-0000	N	-0000	C	-0003
NEM-SSSR-714PGNT-B	14 Way SS Jam Nut Receptacle	078361-0000	A	-0001	D	-0004
NEM-SSSR-719PGNT-B	19 Way SS Jam Nut Receptacle	078363-0000	B	-0002		
Jam Nut Receptacle Location Pegs			Polarisation	Suffix	Polarisation	Suffix
NEM-SSSR-77PGNL-B	7 Way SS Jam Nut Receptacle Location Pegs	078319-0100	N	-0100	C	-0103
NEM-SSSR-714PGNL-B	14 Way SS Jam Nut Receptacle Location Pegs	078321-0100	A	-0101	D	-0104
NEM-SSSR-719PGNL-B	19 Way SS Jam Nut Receptacle Location Pegs	078323-0100	B	-0102		

Nemesis Space Saver NEM-SS

Cable Plug Dimensions					
Contact arrangement	Dimension				
	ø A	B	C	D	E
7 Way	0.630 (16.00)	1.015 (25.77)	0.565 (14.35)	0.154 (3.90)	1.950 (49.52)
14 Way	0.709 (18.00)	1.064 (27.02)	0.581 (14.75)	0.154 (3.90)	2.038 (51.77)
19 Way	0.787 (20.00)	1.103 (28.02)	0.581 (14.75)	0.154 (3.90)	2.117 (53.77)

NOTE: These dimensions to be determined by customer cable requirements.

Jam Nut Receptacle Dimensions (without Location Pegs)		
Contact arrangement	Dimension A	Dimension B
7	0.270 (6.85)	0.827 (21.00)
14	0.328 (8.34)	0.935 (23.75)
19	0.348 (8.85)	0.984 (25.00)

Recommended maximum panel thickness = 2.4 mm customer cable requirements

Standard contact layouts viewed from the mating face

Jam Nut Receptacle Dimensions (Location Peg option)		
Contact arrangement	Dimension A	Dimension B
7	0.270 (6.85)	0.827 (21.00)
14	0.328 (8.34)	0.935 (23.75)
19	0.348 (8.85)	0.984 (25.00)

Recommended maximum panel thickness = 2.4 mm customer cable requirements

Standard contact layouts viewed from the mating face

Nemesis Space Saver NEM-SS

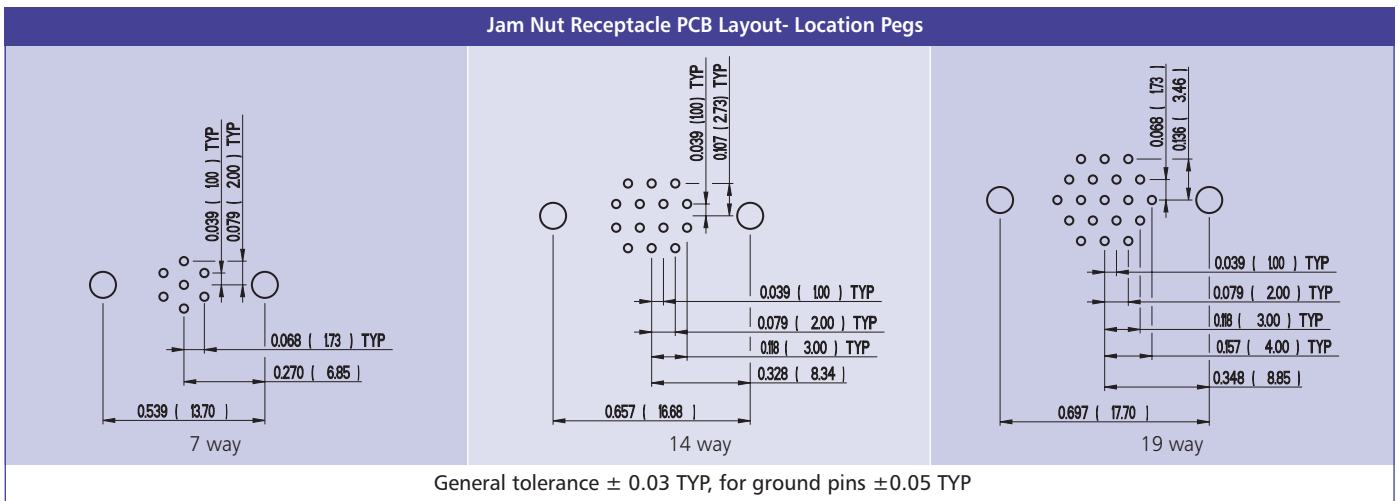
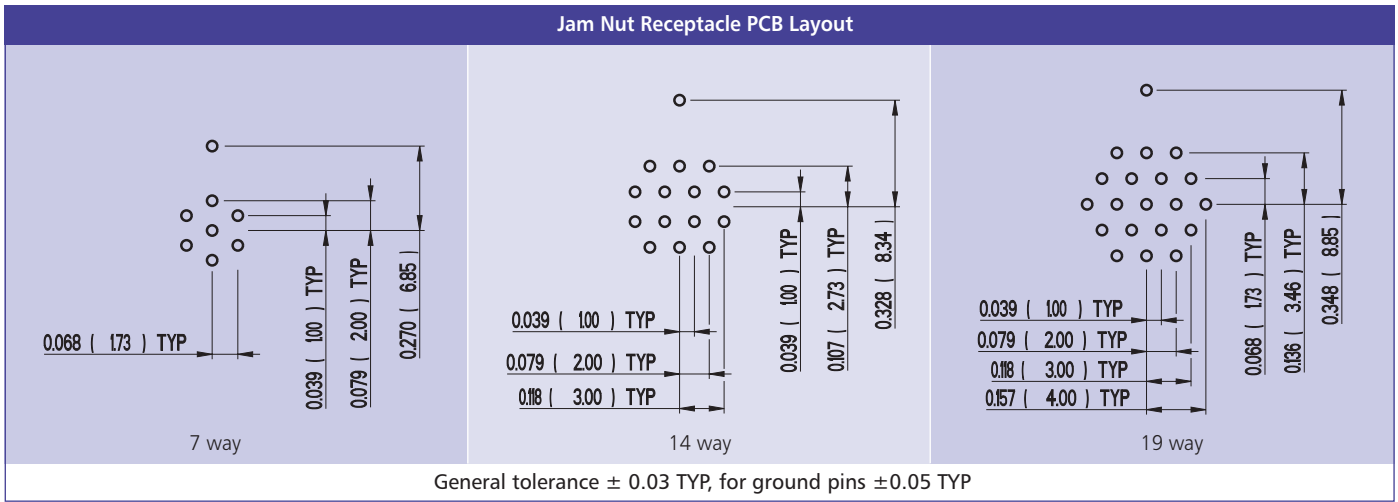

Jam Nut Receptacle Panel Cut-outs

Contact arrangement	Dimension A	Dimension B
7	0.685 (17.40)	0.263 (6.67)
14	0.793 (20.15)	0.323 (8.20)
19	0.843 (21.40)	0.343 (8.70)

Color Coding

Polarisation letter	Color coded paint mark
N	Dark blue
A	Red
B	Green
C	Grey
D	Yellow

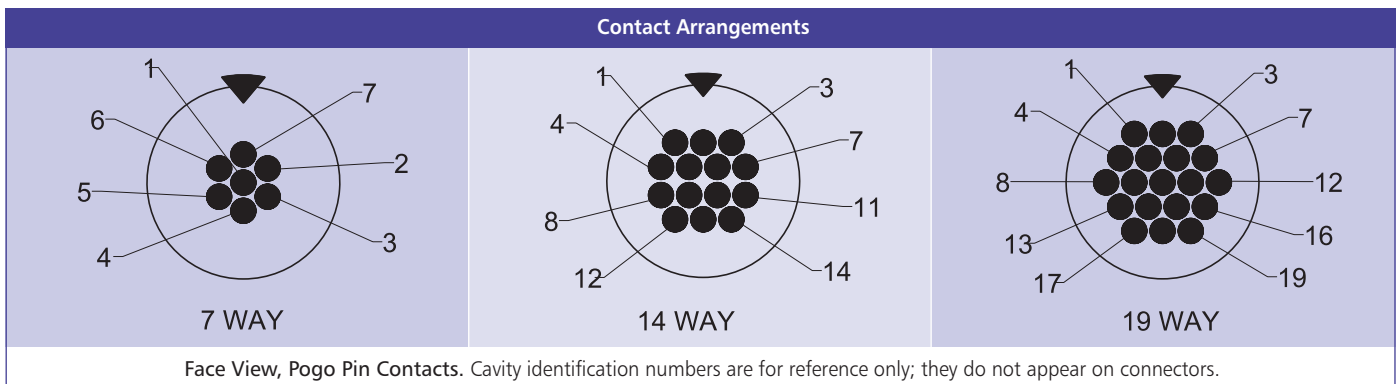

Nemesis Super Clean NEM-SC



Overview

ITT Cannon's Super Clean Connector is a lightweight, robust, watertight and field cleanable** solution designed for military, commercial and industrial applications. The connector features pogo pin technology utilizing ITT's unique spring probe pin/pad contact system for a durable and long life connection.

The cleanable feature allows users to maintain their systems in the field even in the dirtiest of environments.

**Patent Pending

Specifications			
Contact Type	Cable receptacle & plug crimp, Jam nut receptacle PCB	Coupling	Snap-on/Breakaway
		Coding	5 polarizing positions; N, A, B, C, and D
Contacts	Plug = pogo pins, receptacle = pogo pads	Coding Identification	Individual colors with colored dot on both parts plus indication on the boot; N=blue, A=red, B=green, C=grey and D=yellow
Wire Size	24 - 32 AWG		
Contact Rating	2 Amps continuous, 3 Amps peak		
Voltage Rating	50 Vdc		
Insulation Resistance	5 Gohm min (1 Gohm after immersion)	Boot	Cable dependant, either overmoulded or adhered
Dielectric Withstand Voltage	500 Volts	Sealing	IP67
Operating Temperature	-55°C to +125°C	Layouts	7, 14, 19
Contact Resistance	15 mOhm maximum	Shell to Shell Resistance	<20 mOhm
		Blind Mate	Yes
Vibration	20 g's in accordance with MIL-STD-1344 Method 2005, Condition IV	Cable	ITT standard or customer specified
		Cable Earth Termination	360° cable braid termination to the shell
Shock	50 g's in accordance with MIL-STD-1344 Method 2004, Condition E	Snap-on/Breakaway Forces	30N
Durability	10,000 cycles	Strain Relief	Designed to withstand a 10Kg pull off force minimum
Cleaning Durability	2,500 cycles		
Plating	RoHS compliant 500 hour salt spray resistant black zinc nickel or electroless nickel	Materials	Shells - Stainless Steel
			Insulators – High temperature engineering polymer
Receptacle Mounting**	Tamper proof jam nut		Seals - Fluorosilicone rubber
Receptacle Sealing	Using a conductive 'O' ring, non-conductive 'O' rings are available		Contacts - Copper alloy with gold over nickel plating
EMI Shielding	50db attenuation 100Mhz to 1000Mhz in terminated condition		

Nemesis Super Clean NEM-SC – How to Order



Product	NEM-SC		
			NEM - SCSB - 7 14 PG N T - XXX B
Coupling Style:	Cable Plug SB	Receptacle SB	Snap-on/Breakaway
Shell Style:		1	Cable Receptacle
	6		Cable Plug
	7		Jam Nut Receptacle**
Contact Arrangement:	7	7	7
	14	14	
	19	19	
Contact Type:	PG		Pogo Contact
		PP	Pogo Pad Contact
Polarising Positions:	N	N	Normal
	A, B, C & D	A, B, C & D	Alternatives
Termination Type:	C	C***	Crimp Contacts
		T	Straight PCB Tails
Termination Code:	XXX	XXX	See Cable for the Nemesis Connector Range on page 48
Finish Code:	B	B	Black Electroless Nickel
	N	N	Electroless Nickel

Super Clean plugs are intermateable with High Mating receptacles.

** Requires special tool, see Jam Nut Tools on page 44

*** Crimp contacts for Cable Receptacle only

Nomenclature	Description	Part Numbers	Cable Length Part Number Suffixes			
Cable Receptacle			Polarisation/ Length of Cable	Suffix	Polarisation/ Length of Cable	Suffix
NEM-SCSB-17PPNC-001B	7 Way SC Cable Receptacle w 1m cable	078337-0000	N 1m	-0000	C 3m	-0008
NEM-SCSB-114PPNC-004B	14 Way SC Cable Receptacle w 1m cable	078340-0000	A 1m	-0001	D 3m	-0009
NEM-SCSB-119PPNC-007B	19 Way SC Cable Receptacle w 1m cable	078343-0000	B 1m	-0002	N 5m	-0010
			C 1m	-0003	A 5m	-0011
			D 1m	-0004	B 5m	-0012
			N 3m	-0005	C 5m	-0013
NEM-SCSB-619PGNC-007B	19 Way SC Cable Plug w 1m cable	078332-0000	A 3m	-0006	D 5m	-0014
			B 3m	-0007		
Cable Plug			Polarisation	Suffix	Polarisation	Suffix
NEM-SCSB-67PGNC-001B	7 Way SC Cable Plug w 1m cable	078326-0000	N	-0000	C	-0003
NEM-SCSB-614PGNC-004B	14 Way SC Cable Plug w 1m cable	078329-0000	A	-0001	D	-0004
NEM-SCSB-719PPNT-B	19 Way SC Jam Nut Receptacle	078333-0000	B	-0002		

Nemesis Super Clean NEM-SC

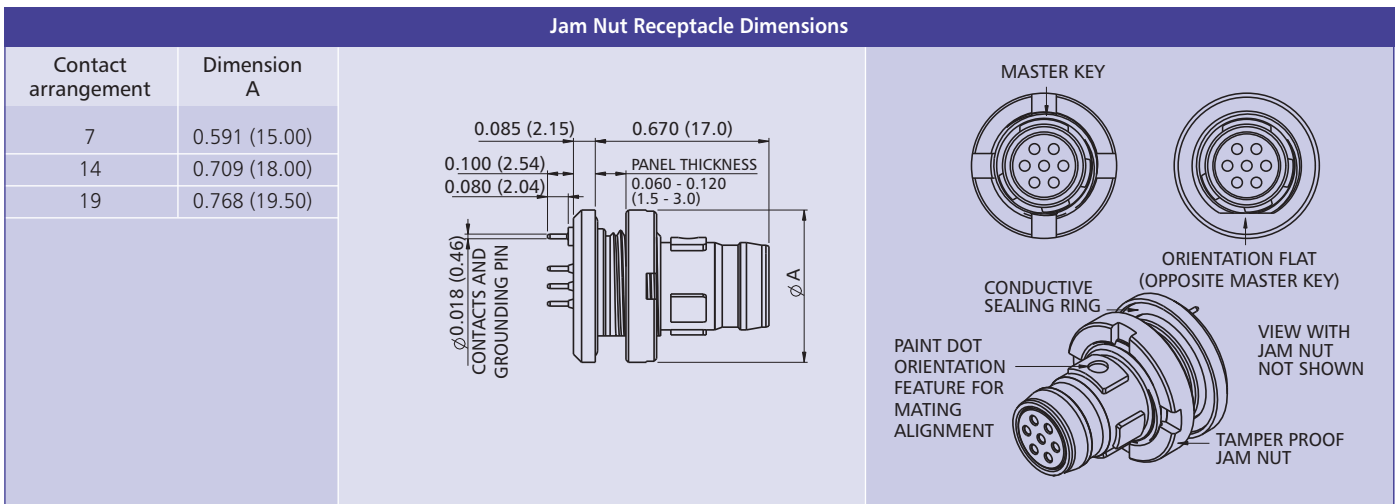
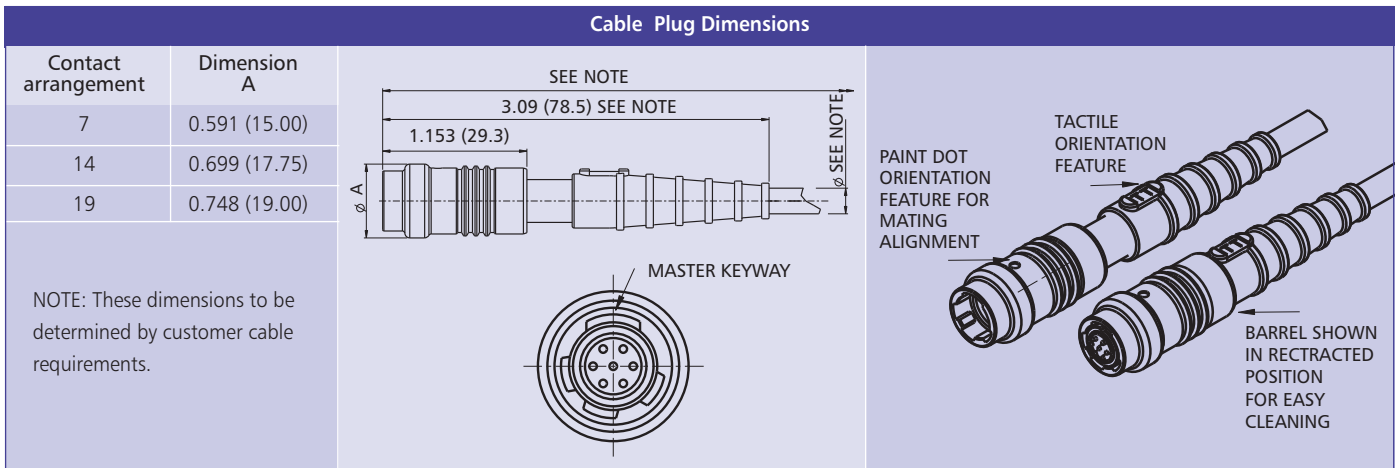
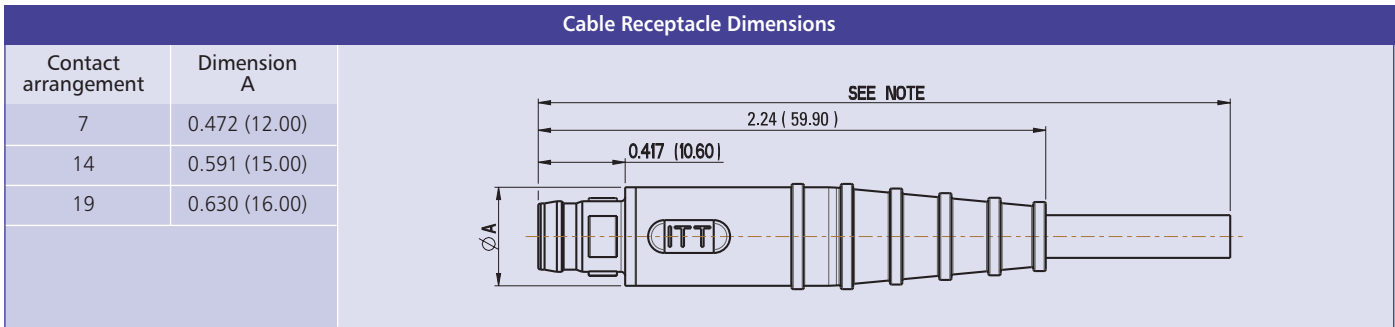

Color Coding

Polarisation letter	Color coding
N	Blue
A	Red
B	Green
C	Grey
D	Yellow

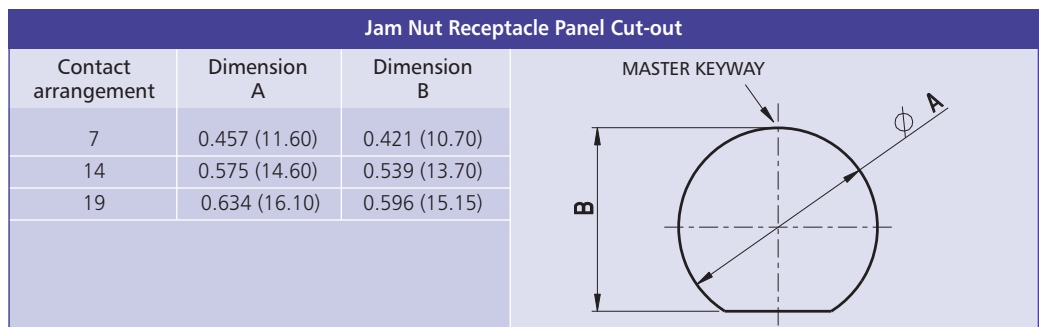

Nemesis Super Clean NEM-SC

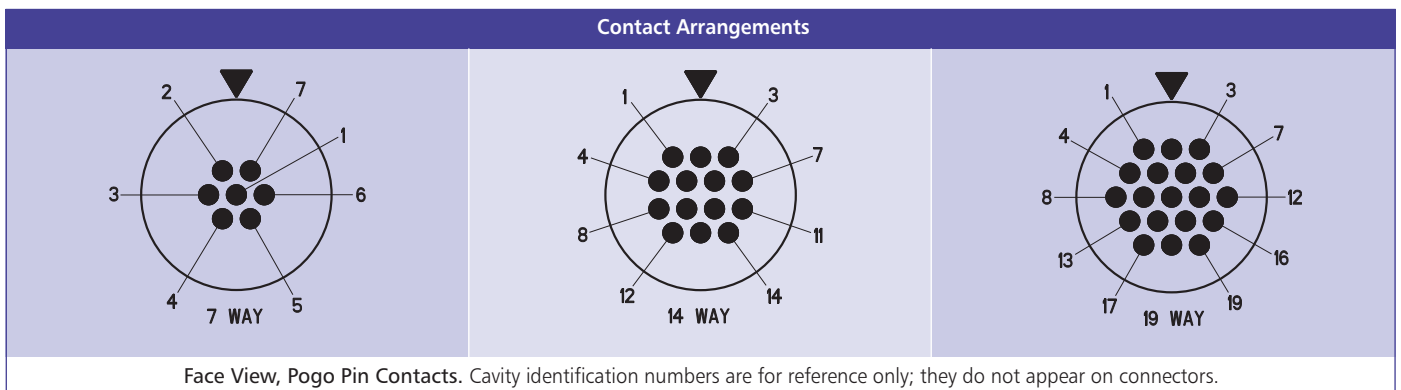
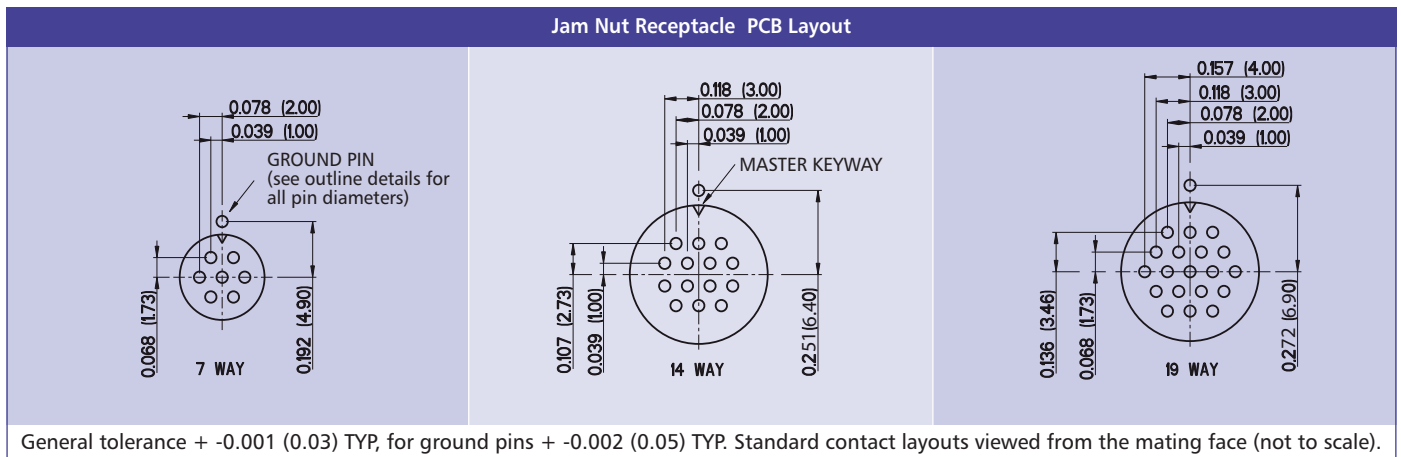

Nemesis High Mating NEM-HM



Overview

ITT Cannon's High Mating Connector is a lightweight, robust, watertight solution designed for military, commercial and industrial applications.

The connector features pogo pin technology utilizing ITT's unique spring probe pin/pad contact system for a durable and long life connection.

Specifications			
Contact Type	Cable receptacle & plug crimp, Jam nut receptacle & plug PCB	Coupling	Snap-on/Breakaway
		Coding	5 polarizing positions; N, A, B, C, and D
Contacts	Plugs = pogo pins, receptacles = pogo pads	Coding Identification	Individual colors with colored dot on both parts plus indication on the boot; N=blue, A=red, B=green, C=grey and D=yellow
Wire Size	24 - 32 AWG		
Contact Rating	2 Amps continuous, 3 Amps peak		
Voltage Rating	50 Vdc	Boot	Cable dependant, either overmoulded or adhered
Insulation Resistance	5 Gohm min (1 Gohm after immersion)	Sealing	IP67
Dielectric Withstand Voltage	500 Volts	Layouts	7, 14, 19
Operating Temperature	-55°C to +125°C	Shell to Shell Resistance	<20 mOhm
Contact Resistance	15 mOhm maximum	Blind Mate	Yes
Vibration	20 g's in accordance with MIL-STD-1344 Method 2005, Condition IV	Cable	ITT standard or customer specified
		Cable Earth Termination	360° cable braid termination to the shell
Shock	50 g's in accordance with MIL-STD-1344 Method 2004, Condition E	Snap-on/Breakaway Forces	30N
		Strain Relief	Designed to withstand a 10Kg pull off force minimum
Durability	10,000 cycles	Materials	Shells - Stainless Steel
Plating	RoHS compliant 500 hour salt spray resistant black zinc nickel or electroless nickel		Insulators – High temperature engineering polymer
Receptacle Mounting**	Tamper proof jam nut		Seals - Fluorosilicone rubber
Receptacle Sealing	Using a conductive 'O' ring, non-conductive 'O' rings are available		Contacts - Copper alloy with gold over nickel plating
EMI Shielding	50db attenuation 100Mhz to 1000Mhz in terminated condition		

Nemesis High Mating NEM-HM – How to Order



Product	NEM-HM		NEM - HMSB - 7 14 PG N T - XXX B							
	Plug	Receptacle								
Coupling Style:	SB	SB	Snap-on/Breakaway							
Shell Style:		1	Cable Receptacle							
	6		Cable Plug							
		7	Jam Nut Receptacle**							
	9		Jam Nut Plug **							
Contact Arrangement:	7	7								
	14	14								
	19	19								
Contact Type:	PG		Pogo Contact							
		PP	Pogo Pad Contact							
Polarising Positions:	N	N	Normal							
	A, B, C & D	A, B, C & D	Alternatives							
Termination Type:	C	C***	Crimp Contacts							
	T****	T	Straight PCB Tails							
Termination Code:	XXX	XXX	See Cable for the Nemesis Connector Range on page 48							
Finish Code:	B	B	Black Electroless Nickel							
	N	N	Electroless Nickel							

High Mating plugs are intermateable with Super Clean receptacles. If this is not suitable for your application non-preferred V, W, X, Y & Z coding may be used, contact sales for availability

** Requires special tool, see Jam Nut Tools on page 44

*** Crimp contacts for Cable receptacles only

**** Straight PC Tails for Jam Nut Plug only

Nomenclature	Description	Part Numbers	Cable Length Part Number Suffixes				
Cable Receptacle			Polarisation/ Length of Cable		Polarisation/ Length of Cable		
NEM-HMSB-17PPNC-001B	7 Way HM Cable Receptacle w 1m cable	078328-0000	N 1m	-0000	C 3m-	0008	
NEM-HMSB-114PPNC-004B	14 Way HM Cable Receptacle w 1m cable	078331-0000	A 1m	-0001	D 3m	-0009	
NEM-HMSB-119PPNC-007B	19 Way HM Cable Receptacle w 1m cable	078334-0000	B 1m	-0002	N 5m	-0010	
Cable Plug			C 1m	-0003	A 5m	-0011	
			D 1m	-0004	B 5m	-0012	
	NEM-HMSB-67PGNC-001B	7 Way HM Cable Plug w 1m cable	078335-0000	N 3m	-0005	C 5m	-0013
	NEM-HMSB-614PGNC-004B	14 Way HM Cable Plug w 1m cable	078338-0000	A 3m	-0006	D 5m	-0014
NEM-HMSB-619PGNC-007B	19 Way HM Cable Plug w 1m cable	078341-0000	B 3m	-0007			
Jam Nut Receptacle			Polarisation	Suffix	Polarisation	Suffix	
NEM-HMSB-77PPNT-B	7 Way HM Jam Nut Receptacle	078336-0000	N	-0000	C	-0003	
NEM-HMSB-714PPNT-B	14 Way HM Jam Nut Receptacle	078339-0000	A	-0001	D	-0004	
NEM-HMSB-719PPNT-B	19 Way HM Jam Nut Receptacle	078342-0000	B	-0002			
Jam Nut Plug							
NEM-HMSB-97PGNT-B	7 way HM Jam Nut Plug	078344-0000					
NEM-HMSB-914PGNT-B	14 way HM Jam Nut Plug	078345-0000					
NEM-HMSB-919PGNT-B	19 way HM Jam Nut Plug	078346-0000					

Nemesis High Mating NEM-HM

Cable Receptacle Dimensions	
Contact arrangement	Dimension A
7	0.472 (12.00)
14	0.591 (15.00)
19	0.630 (16.00)

Cable Plug Dimensions	
Contact arrangement	Dimension A
7	0.591 (15.00)
14	0.699 (17.75)
19	0.748 (19.00)

NOTE: These dimensions to be determined by customer cable requirements.

Jam Nut Receptacle Dimensions	
Contact arrangement	Dimension A
7	0.591 (15.00)
14	0.709 (18.00)
19	0.768 (19.50)

Color Coding	
Polarisation letter	Color coding
N	Blue
A	Red
B	Green
C	Grey
D	Yellow

Jam Nut Receptacle Panel Cut-out		
Contact arrangement	Dimension A	Dimension B
7	0.457 (11.60)	0.421 (10.70)
14	0.575 (14.60)	0.539 (13.70)
19	0.634 (16.10)	0.596 (15.15)

Nemesis High Mating NEM-HM



Jam Nut Receptacle PCB Layout

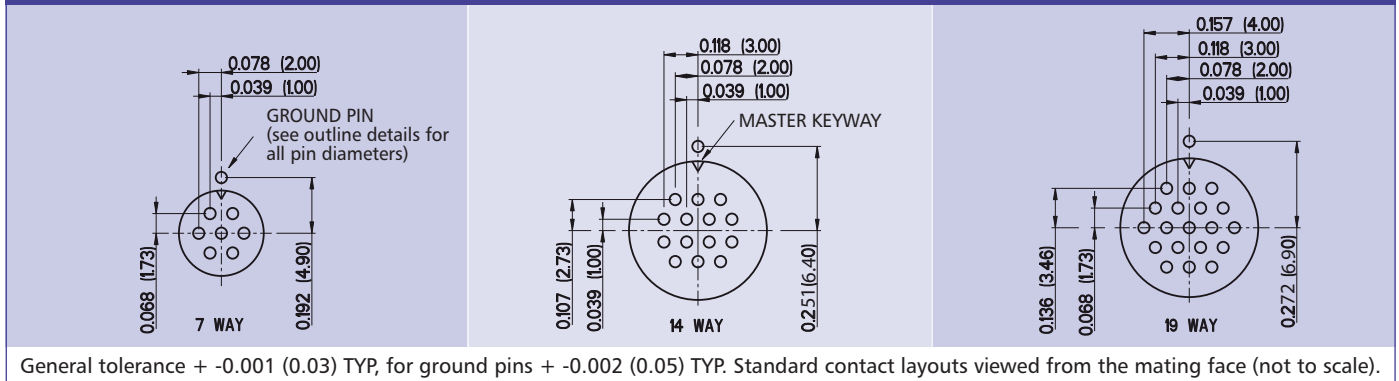

Jam Nut Plug Dimensions

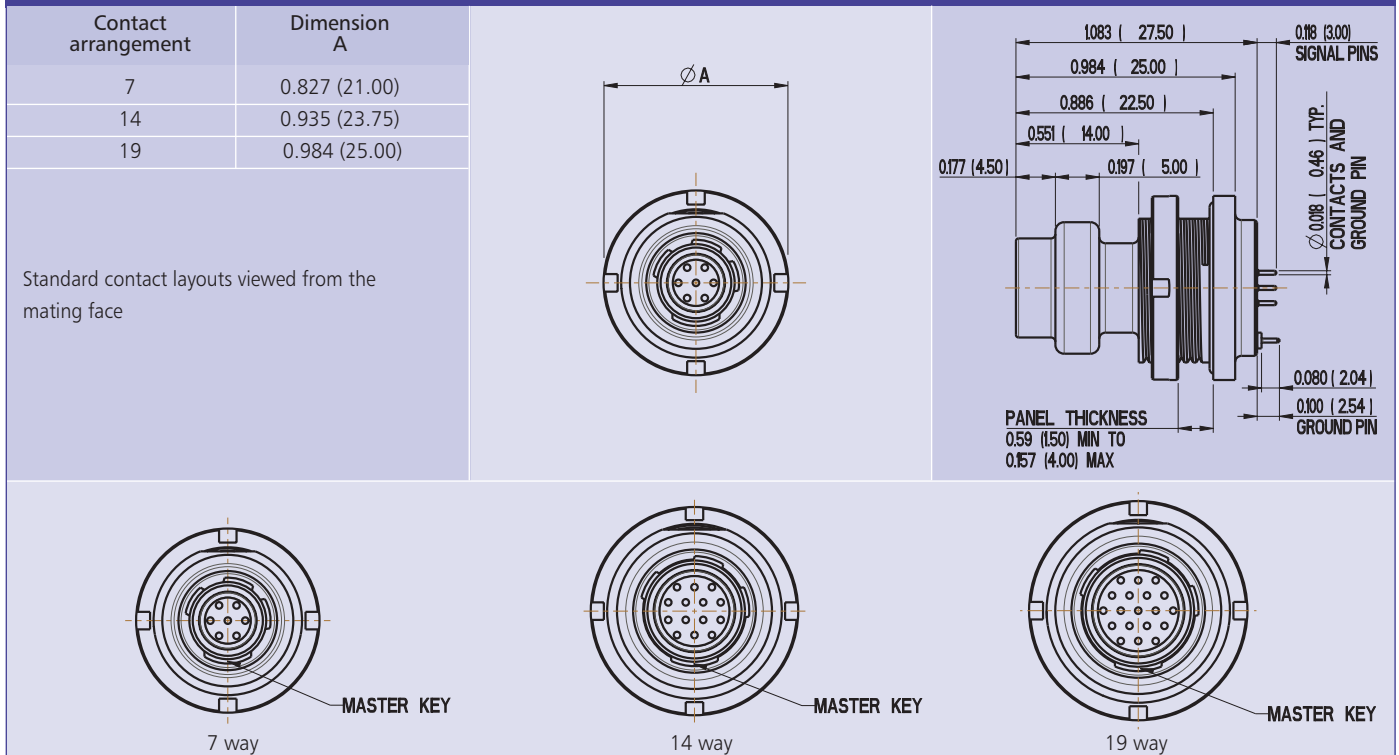

Jam Nut Plug Panel Cut-out

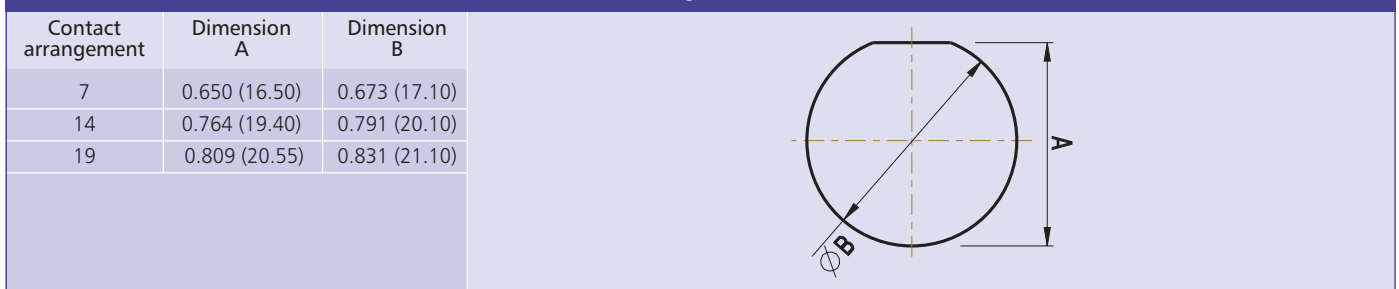

Nemesis High Mating NEM-HM

Jam Nut Plug PCB Layout

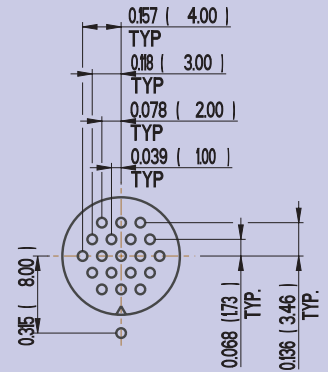
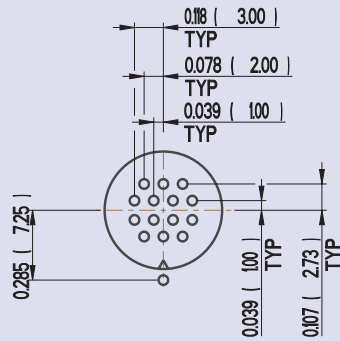
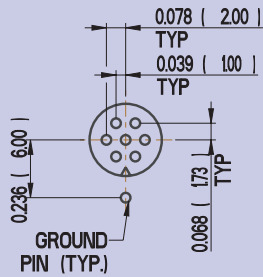

General tolerance + -0.001 (0.03) TYP, for ground pins + -0.002 (0.05) TYP. Standard contact layouts viewed from the mating face (not to scale).

Contact Arrangements

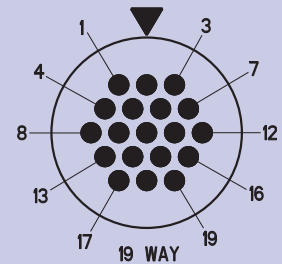
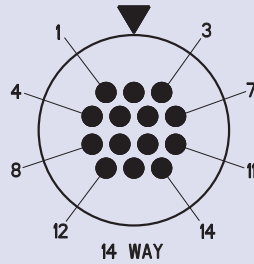
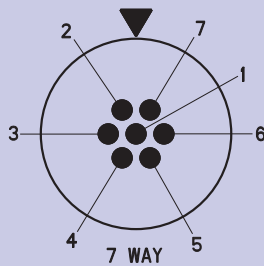

Face View, Pogo Pin Contacts. Cavity identification numbers are for reference only; they do not appear on connectors.

Nemesis Water Tight NEM-WT



Overview

ITT Cannon's Water Tight connector is a lightweight, robust and watertight solution designed for military, marine, medical and industrial application.

The connector features micro twist pin contact technology and as its name implies the connector is rated for an immersion depth of greater than 20 meters of water.

Specifications			
Contact Type	Cable plug and cable receptacle crimp, jam nut receptacle PCB	Coupling	Snap-on/Breakaway & push pull
		Coding	5 polarizing positions; N, A, B, C, and D
Contacts	Cable plug and free jam nut receptacle micro twist pin, receptacle micro socket	Coding Identification	Individual colors with colored dot on both parts plus indication on the boot; N=blue, A=red, B=green, C=grey and D=yellow
Wire Size	24 - 32 AWG	Boot	Cable dependant, either overmoulded or adhered
Contact Rating	3 Amps	Sealing	IP68, >20m
Voltage Rating	50 Vdc	Layouts	3 layouts, 7, 14 & 19 contacts
Insulation Resistance	5 Gohm min (1 Gohm after immersion)	Shell to Shell Resistance	<20 mOhm (Snap-on/Breakaway) <50 mOhm (Push Pull)
Dielectric Withstand Voltage	500 Volts	Blind Mate	Yes
Operating Temperature	-40°C to +100°C	Cable	ITT standard or customer specified
Contact Resistance	8 mOhm maximum	Cable Earth Termination	360° cable braid termination to the shell
Vibration	20 g's in accordance with MIL-STD-1344 Method 2005, Condition IV	Snap-on/Breakaway Forces	30N
Shock	50 g's in accordance with MIL-STD-1344 Method 2004, Condition E	Strain Relief	Designed to withstand a 10Kg pull off force minimum
Durability	2,500 cycles (500 cycles Push Pull)	Materials	Shells - Stainless Steel Insulators – High temperature engineering polymer Seals - Fluorosilicone rubber Contacts - Copper alloy with gold over nickel plating
Shell Plating	RoHS compliant 500 hour salt spray resistant black zinc nickel or electroless nickel		
Receptacle Mounting**	Tamper proof jam nut		
Receptacle Sealing	Using a conductive 'O' ring, non-conductive 'O' rings are available		
EMI Shielding	50db attenuation 100Mhz to 1000Mhz in terminated condition		

Nemesis Water Tight NEM-WT- How to Order

Product	NEM-WT		NEM - WTSB - 7 14 S N T - XXX B									
Coupling Style:	Plug	Receptacle	SB	SB	Snap-on/Breakaway							
	PP	PP			Push Pull							
Shell Style:		1			Cable Receptacle (PP not available)							
	6				Cable Plug							
		7			Jam Nut Receptacle**							
Contact Arrangement:	7	7										
	14	14										
	19	19										
Contact Type:	P				Pin Contact							
		S			Socket Contact							
Polarising Positions:	N	N			Normal							
	A, B, C & D	A, B, C & D			Alternatives							
Termination Type:	C	C***			Crimp Contacts							
		T			Straight PCB Tails							
Termination Code:	XXX	XXX			See Cable for the Nemesis Connector Range on page 48							
Finish Code:	B	B			Black Electroless Nickel							
	N	N			Electroless Nickel							

* 7, 14 & 19 way connectors use the same colour coding system but have different polarization. Where duplicate contact layouts are required on the same equipment it is recommended different polarization is used.

** Requires special tool, see Jam Nut Tools on page 44

***Crimp contacts for Cable Receptacle only.

Nomenclature	Description	Part Numbers	Cable Length Part Number Suffixes			
Cable Receptacle			Polarisation/ Length of Cable	Suffix	Polarisation/ Length of Cable	Suffix
NEM-WTSB-17SNC-001B	7 Way WT Cable Receptacle w 1m cable	078312-0000	N 1m	-0000	C 3m	-0008
NEM-WTSB-114SNC-004B	14 Way WT Cable Receptacle w 1m cable	078313-0000	A 1m	-0001	D 3m	-0009
NEM-WTSB-119SNC-007B	19 Way WT Cable Receptacle w 1m cable	078314-0000	B 1m	-0002	N 5m	-0010
			C 1m	-0003	A 5m	-0011
Cable Plug			D 1m	-0004	B 5m	-0012
NEM-WTSB-67PNC-001B	7 Way WT SB Cable Plug w 1m cable	078281-0000	N 3m	-0005	C 5m	-0013
NEM-WTPP-67PNC-001B	7 Way WT PP Cable Plug w 1m cable	078354-0000	A 3m	-0006	D 5m	-0014
NEM-WTSB-614PNC-004B	14 Way WT SB Cable Plug w 1m cable	078282-0000	B 3m	-0007		
NEM-WTPP-614PNC-004B	14 Way WT PP Cable Plug w 1m cable	078355-0000				
NEM-WTSB-619PNC-007B	19 Way WT SB Cable Plug w 1m cable	078283-0000				
NEM-WTPP-619PNC-007B	19 Way WT PP Cable Plug w 1m cable	078356-0000				
Jam Nut Receptacle			Polarisation	Suffix	Polarisation	Suffix
NEM-WTSB-77SNT-B	7 Way WT SB Jam Nut Receptacle	078280-0000	7 way N	-0000	14 way C	-0008
NEM-WTPP-77SNT-B	7 Way WT PP Jam Nut Receptacle	078353-0000	7 way A	-0001	14 way D	-0009
NEM-WTSB-714SNT-B	14 Way WT SB Jam Nut Receptacle	078280-0005	7 way B	-0002	19 way N	-0010
NEM-WTPP-714SNT-B	14 Way WT PP Jam Nut Receptacle	078353-0005	7 way C	-0003	19 way A	-0011
NEM-WTSB-719SNT-B	19 Way WT SB Jam Nut Receptacle	078280-0010	7 way D	-0004	19 way B	-0012
NEM-WTPP-719SNT-B	19 Way WT PP Jam Nut Receptacle	078353-0010	14 way N	-0005	19 way C	-0013
			14 way A	-0006	19 way D	-0014
			14 way B	-0007		

Nemesis Water Tight NEM-WT

Jam Nut Receptacle Dimensions - Push Pull

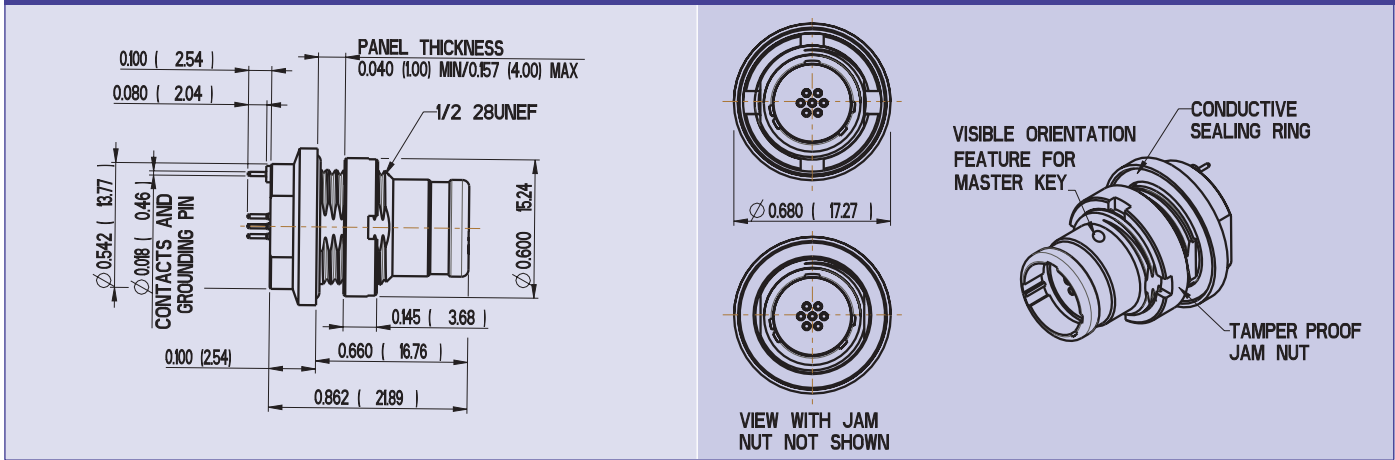

Color Coding

Polarisation letter	Color coding
N	Blue
A	Red
B	Green
C	Grey
D	Yellow

Jam Nut Receptacle Panel Cut-outs

Contact arrangement	Dimension A	Dimension B
7	0.455 (11.56)	0.501 (12.73)
14	0.455 (11.56)	0.501 (12.73)
19	0.455 (11.56)	0.501 (12.73)

Diagram of a panel cut-out showing dimensions A and B MIN.

Jam Nut Receptacle PCB Layout

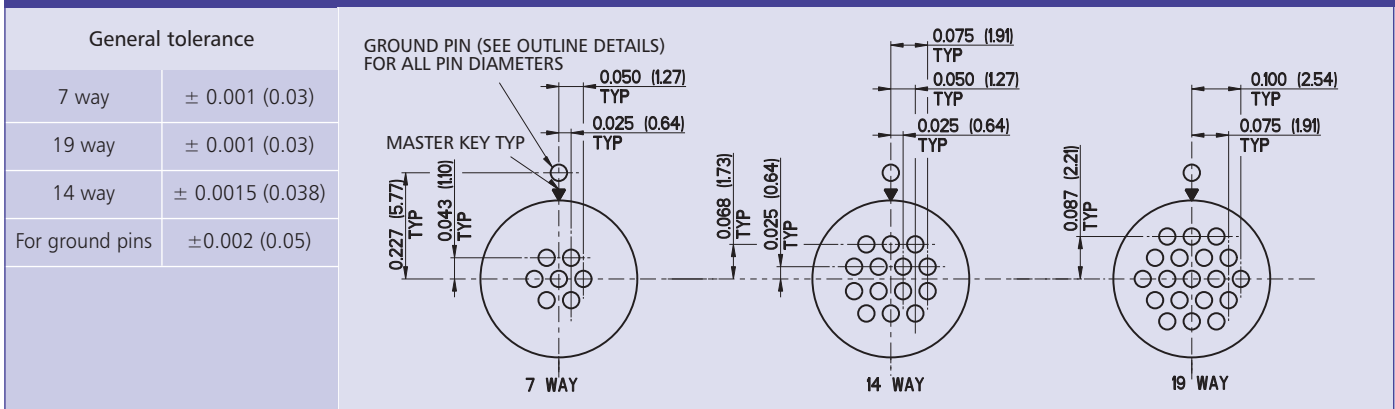

Contact Arrangements

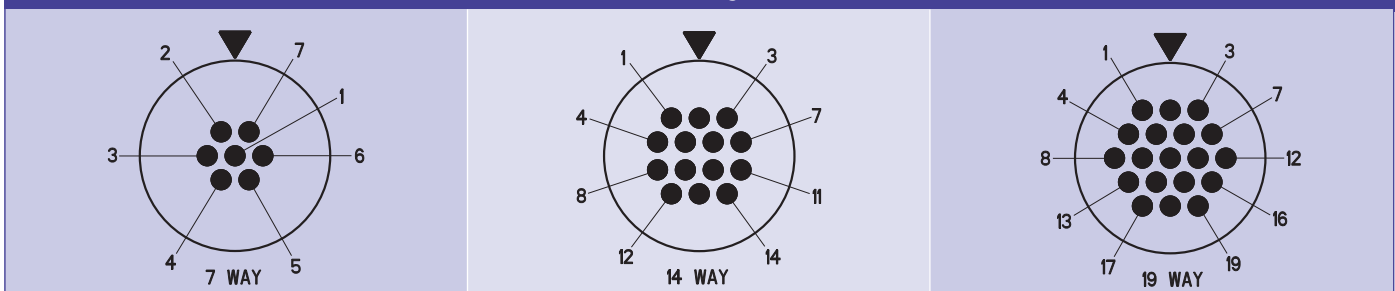

Face View, Pin Contacts. Cavity identification numbers are for reference only; they do not appear on connectors.

Nemesis Accessories – EMI Caps

How to order



Product Nemesis EMI Caps for HM/QT/QTHS/SC/SS

NEM - SB - EC 7 14 - B

Coupling Style:	Receptacle	
	SB	Snap-on / Breakaway (HM/QT/QTHS/SC)
	SS	Space Saver
Cap Style:	EC	EMI cap
Shell Style:	7	
Contact Arrangement:	7, 14, 19	Way
Finish Code:	B	Black Electroless Nickel

Nomenclature	Description	Part Numbers
EMI Caps		
NEM-SB-EC-77-B	7 / 8 Way Snap-on/Breakaway EMI Cap	078418-0000
NEM-SB-EC-714-B	14 Way Snap-on/Breakaway EMI Cap	078418-1000
NEM-SB-EC-719-B	19 Way Snap-on/Breakaway EMI Cap	078418-2000
Space Saver EMI Caps		
NEM-SS-EC-77-B	7 Way Space Saver EMI Cap	078417-0000
NEM-SS-EC-714-B	14 Way Space Saver EMI Cap	078417-1000
NEM-SS-EC-719-B	19 Way Space Saver EMI Cap	078417-2000



Snap-on / Breakaway Receptacle EMI Caps		
Contact arrangement	Dimension A	Dimension B
7	0.669 (17.00)	0.472 (12.00)
14	0.776 (19.70)	0.591 (15.00)
19	0.827 (21.00)	0.650 (16.50)

Space Saver Receptacle EMI Caps		
Contact arrangement	Dimension A	Dimension B
7 / 8	0.709 (18.00)	0.685 (17.40)
14	0.827 (21.00)	0.803 (20.40)
19	0.866 (22.00)	0.843 (21.40)

- Notes: 1. Dimensions are nominal unless stated otherwise. 2. Material: Cap – Stainless Steel
Cord – Polyester
Ring – Stainless Steel
Crimp Rings – Copper 3. Finish: Black Electroless Nickel

Nemesis Accessories – Dust Caps

How to order

Product Nemesis Dust Caps for HM/QT/QTHS/SC/WT

NEM - WTPP - DC 6 7

Coupling Style:	Plug	Receptacle	
	WTPP	WT	Water Tight Push Pull
	WTSB	WT	Water Tight Snap-on / Breakaway
	SB	SB	Snap-on / Breakaway (HM/QT/QTHS/SC)
Cap Style:	DC	DC	Dust cap
Shell Style:	6	7	
Contact Arrangement:	7, 14, 19	7, 14, 19	Way



Nomenclature	Description	Part Numbers	Quantity
Cable Plug Dust Cap			
NEM-WTPP-DC-6-7	7 Way Water Tight Push Pull Cable Plug	078411-0000	25
NEM-WTPP-DC-6-14	14 Way Water Tight Push Pull Cable Plug	078411-1000	25
NEM-WTPP-DC-6-19	19 Way Water Tight Push Pull Cable Plug	078411-2000	25
NEM-WTSB-DC-6-7	7 Way Water Tight Snap-on/Breakaway Cable Plug	078409-0000	25
NEM-WTSB-DC-6-14	14 Way Water Tight Snap-on/Breakaway Cable Plug	078409-1000	25
NEM-WTSB-DC-6-19	19 Way Water Tight Snap-on/Breakaway Cable Plug	078409-2000	25
NEM-SB-DC-6-7	7 Way Snap-on/Breakaway Cable Plug	078405-0000	25
NEM-SB-DC-6-14	14 Way Snap-on/Breakaway Cable Plug	078405-1000	25
NEM-SB-DC-6-19	19 Way Snap-on/Breakaway Cable Plug	078405-2000	25
Jam Nut Receptacle			
NEM-WT-DC-77/14/19	7/14/19 Way Water Tight Push Pull & Snap-on/Breakaway Jam Nut Receptacle	078410-0000	25
NEM-SB-DC-77	7 Way Snap-on/Breakaway Jam Nut Receptacle	078406-0000	25
NEM-SB-DC-714	14 Way Snap-on/Breakaway Jam Nut Receptacle	078406-1000	25
NEM-SB-DC-719	19 Way Snap-on/Breakaway Jam Nut Receptacle	078406-2000	25



Cable Plug Dust Caps			
TYPE	Dimension A	Dimension B	Contact arrangement
Water Tight Push Pull	1.071 (27.2)	0.217 (5.5)	7
Water Tight Push Pull	1.071 (27.2)	0.307 (7.8)	14
Water Tight Push Pull	1.071 (27.2)	0.315 (8.0)	19
Water Tight Snap-on / Breakaway	0.906 (23.0)	0.217 (5.5)	7
Water Tight Snap-on / Breakaway	0.906 (23.0)	0.307 (7.8)	14
Water Tight Snap-on / Breakaway	0.906 (23.0)	0.315 (8.0)	19
High Mating / Super Clean	0.787 (20.0)	0.217 (5.5)	7
High Mating / Super Clean	0.906 (23.0)	0.307 (7.8)	14
High Mating / Super Clean	0.945 (24.0)	0.315 (8.0)	19

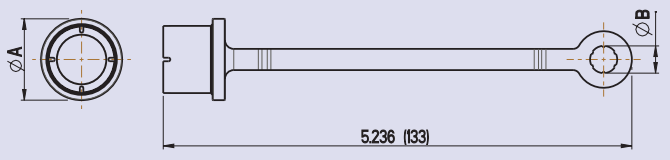



Jam Nut Receptacle Dust Caps			
TYPE	Dimension A	Dimension B	Contact arrangement
Water Tight Push Pull & Snap-on / Breakaway	0.695 (17.65)	0.528 (13.40)	7,14,19
High Mating / Super Clean	0.537 (13.65)	0.472 (12.00)	7
High Mating / Super Clean	0.646 (16.4)	0.591 (15.00)	14
High Mating / Super Clean	0.736 (18.7)	0.650 (16.50)	19

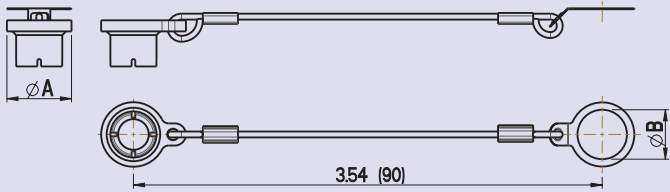

Notes: 1. Dimensions are nominal unless stated otherwise.
 2. Material: Cap – Santoprene
 Cord – Polyester
 Ring – Stainless Steel
 Crimp Rings – Copper

Nemesis - Accessories

Jam Nut Tools



Jam Nut Tools				
Product	Number of ways	Tool part number	Diameter A	Diameter B
Water Tight	7, 14, 19	T4909/01	0.505 (12.83)	0.625 (15.88)
High Mating Super Clean Jam Nut Receptacle	7	T4909/02	0.443 (11.25)	0.625 (15.88)
High Mating Super Clean Jam Nut Receptacle	14	T4909/03	0.568 (14.43)	0.740 (18.80)
High Mating Super Clean Jam Nut Receptacle	19	T4909/04	0.630 (16.00)	0.800 (20.32)
High Mating Jam Nut Plug	7	T4910/01	0.675 (17.15)	0.835 (21.21)
High Mating Jam Nut Plug	14	T4910/02	0.792 (20.12)	0.943 (23.95)
High Mating Jam Nut Plug	19	T4910/03	0.832 (21.13)	0.992 (25.20)
Space Saver	7	T4910/01	0.675 (17.15)	0.835 (21.21)
Space Saver	14	T4910/02	0.792 (20.12)	0.943 (23.95)
Space Saver	19	T4910/03	0.832 (21.13)	0.992 (25.20)

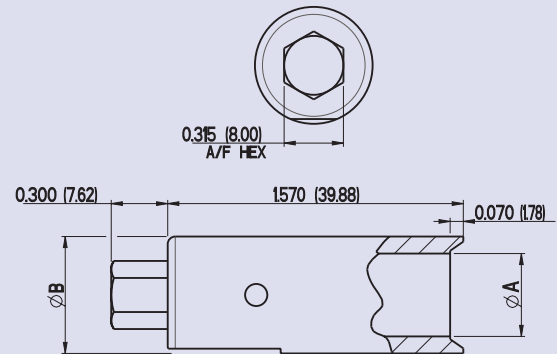

Material: Silver Steel

Finish: Nickel

Torque Settings		
Product Range	Number of ways	Torque Setting
HM	7, 14 & 19	15/18 lb.ins. (1.70/2.03 NM)
QT	7, 14 & 19	15/18 lb.ins. (1.70/2.03 NM)
QTHS	8, 14 & 19	15/18 lb.ins. (1.70/2.03 NM)
SC	7, 14 & 19	15/18 lb.ins. (1.70/2.03 NM)
SS	7, 14 & 19	27/29 lb.ins. (3.10/3.30 NM)
WT	7, 14 & 19	15/18 lb.ins. (1.70/2.03 NM)

Nemesis Connector Range – Weight Data



Nemesis Connector Range – Weight					
Cable Plug (includes over mould, less cable (not QT/QTHS))	Number of ways	Weight (grammes)	Jam Nut Receptacle	Number of ways	Weight (grammes)
High Mating	7	16.50	High Mating	7	8.60
High Mating	14	22.00	High Mating	14	12.50
High Mating	19	24.00	High Mating	19	15.10
Quick Term / Quick Term High Speed	7/8	7.80	Quick Term / Quick Term High Speed	7/8	8.60
Quick Term / Quick Term High Speed	14	11.50	Quick Term / Quick Term High Speed	14	12.20
Quick Term / Quick Term High Speed	19	14.00	Quick Term / Quick Term High Speed	19	14.70
Super Clean	7	25.00	Super Clean	7	8.60
Super Clean	14	30.50	Super Clean	14	12.50
Super Clean	19	42.00	Super Clean	19	15.10
Space Saver	7	9.60	Space Saver	7	10.20
Space Saver	14	11.60	Space Saver	14	17.40
Space Saver	19	14.80	Space Saver	19	19.00
Water Tight Snap-on / Breakaway	7	21.50	Water Tight Snap-on / Breakaway	7	11.25
Water Tight Snap-on / Breakaway	14	25.00	Water Tight Snap-on / Breakaway	14	11.35
Water Tight Snap-on / Breakaway	19	25.25	Water Tight Snap-on / Breakaway	19	11.40
Water Tight Push Pull	7	36.00	Water Tight Push Pull	7	12.60
Water Tight Push Pull	14	40.00	Water Tight Push Pull	14	13.10
Water Tight Push Pull	19	40.25	Water Tight Push Pull	19	13.45
Cable Receptacle (includes over mould, less cable (not QT/QTHS))	Number of ways	Weight (grammes)	Backshells for QT/QTHS	Number of ways	Weight (grammes)
High Mating/Super Clean	7	14,05	448-7873-001	7/8	9,64
High Mating/Super Clean	14	19,90	448-7873-002	7/8	9,80
High Mating/Super Clean	19	23,20	448-7873-003	7/8	9,95
Quick Term/Quick Term High Speed	7/8	11,70	448-7873-004	14	11,85
Quick Term/Quick Term High Speed	14	16,30	448-7873-005	14	12,03
Quick Term/Quick Term High Speed	19	20,05	448-7873-006	14	12,93
			448-7873-007	19	13,87
			448-7873-008	19	14,05
			448-7873-009	19	14,22

Cannon Break Away Connector Range – Weight Data

CBA Connector Range – Weight				
In-Line Receptacle Weights (Max Weight In Grams)				
Layout	Banding Platform		Accessory Thread	
	Pin, Pogo Solder Bucket	Pad, Pogo Solder Bucket	Pin, Pogo Solder Bucket	Pad, Pogo Solder Bucket
5-3	5,1	5,3	4,9	5,2
6-4	6,5	6,9	6,4	6,9
6-7	7,1	7,7	6,5	7,7
7-10	9,0	9,9	8,9	10,1
9-19	13,6	15,4	14,0	15,8
12-37	21,6	22,3	21,8	24,3
Straight Plug Weights (Max Weight In Grams)				
Layout	Banding Platform		Accessory Thread	
	Pin, Pogo Solder Bucket	Pad, Pogo Solder Bucket	Pin, Pogo Solder Bucket	Pad, Pogo Solder Bucket
5-3	2,4	2,6	2,3	2,4
6-4	3,1	3,2	3,0	3,5
6-7	3,7	4,4	3,6	4,2
7-10	5,4	6,4	5,5	6,4
9-19	10,7	10,6	8,9	10,7
12-37	16,3	19,8	15,2	19,8
Jam Nut Plug Weights (Max Weight In Grams)				
Layout	Pin, Pogo PC Tail		Pad, Pogo PC Tail	
5-3	5,8		5,8	
6-4	7,1		7,2	
6-7	7,5		8,6	
7-10	9,8		12	
9-19	13,9		19,1	
12-37	20,8		31,5	

Cable for the Nemesis Connector Range – Specification



Specifications			
7, 14, 19 Position Conductors	19/0.10 mm (0.15 sqmm) tinned copper Insulated to 0.90 mm	Secondary Screen	Tinned Copper Wire Braid Nominal optical coverage 80%
Strain member	1.2 mm Braided polyester cord	Maximum conductor resistance	138 /km @ 20°C
Primary screen	Overall helical 12/12µm Al/PET foil laminate Screen, minimum overlap 25% aluminium Face OUT	Minimum insulation resistance	Core-core > 500 M /KM @ 500V Core screen > 250 M /KM @ 500V
		Maximum working voltage	500 Vrms
		Temperature Range	-40°C to +125°C

Contact layout	Calculated weight	Minimum ultimate tensile strength	Maximum recommended pulling force	Jacket Ø	Minimum recommended bend radius	Secondary screen tinned copper wire braid nominal coverage 80%	Jacket thermoplastic vulcanite 70 shore A RTI non-reflective matt finish
7	39 KG/KM	32 KGF (314 N)	11 KGF (108 N)	5.2±0.20	Static:33mm Dynamic:55mm	16/6/0.10mm	0.80mm
14	82 KG/KM	30 KGF (196 N)	15 KGF (147 N)	7.5±0.20	Static:50mm Dynamic:92mm	16/7/0.127mm	1.00mm
19	83 KG/KM	32 KGF (314 N)	11 KGF (108 N)	7.6±0.20	Static:50mm Dynamic:82mm	24/7/0.127mm	1.00mm

Cable for the Nemesis Connector Range – Termination Codes		
Code	No. of Cores	Length (Meters)
001	7	1
002	7	3
003	7	5
004	14	1
005	14	3
006	14	5
007	19	1
008	19	3
009	19	5

Cable Cut length tolerance (mm) +25/-0

Nomenclature Generation	
Example - NEM-WTSB-614PNC-005B = Water Tight, Snap-on/Breakaway, Plug, 14 Way, Pin contact, Normal keyway, Crimp contact, 3M cable, Black Electroless Nickel finish.	
Series:	Water Tight (WT), Super Clean (SC) or High Mate (HM)
Coupling Style:	Snap-on/Breakaway (SB) or Push Pull (PP)
Shell Style:	Free Receptacle (1), Plug (6), Jam Nut receptacle (7) or RA Plug (8)
Contact Arrangement:	7, 14 or 19 Contacts
Contact Type:	Pin (P), Socket (S), Pogo Pin (PG), Pogo Pad (PP)
Polarising Positions:	Normal, A, B, C & D
Termination Type:	Crimp (C) or Straight PCB Tails (T)
Termination Code:	XXX Cable Description
Finish Code:	Black Electroless Nickel (B) or Electroless Nickel Plating (N)

Connection Systems																																												
<p>Connector pin out detail – 7 Way:</p> <table border="0"> <tr><td>Pin 1. Red</td><td>Pin 5. Green</td></tr> <tr><td>Pin 2. Black</td><td>Pin 6. Orange</td></tr> <tr><td>Pin 3. White</td><td>Pin 7. Blue</td></tr> <tr><td>Pin 4. Yellow</td><td></td></tr> </table>	Pin 1. Red	Pin 5. Green	Pin 2. Black	Pin 6. Orange	Pin 3. White	Pin 7. Blue	Pin 4. Yellow		<p>Connector pin out detail – 14 Way:</p> <table border="0"> <tr><td>Pin 1. Pink</td><td>Pin 8. Grey</td></tr> <tr><td>Pin 2. Orange</td><td>Pin 9. Black</td></tr> <tr><td>Pin 3. Dark Blue</td><td>Pin 10. Yellow</td></tr> <tr><td>Pin 4. Dark Brown</td><td>Pin 11. Violet</td></tr> <tr><td>Pin 5. Red</td><td>Pin 12. Light Brown</td></tr> <tr><td>Pin 6. Light Green</td><td>Pin 13. White</td></tr> <tr><td>Pin 7. Dark Green</td><td>Pin 14. Light Blue</td></tr> </table>	Pin 1. Pink	Pin 8. Grey	Pin 2. Orange	Pin 9. Black	Pin 3. Dark Blue	Pin 10. Yellow	Pin 4. Dark Brown	Pin 11. Violet	Pin 5. Red	Pin 12. Light Brown	Pin 6. Light Green	Pin 13. White	Pin 7. Dark Green	Pin 14. Light Blue	<p>Connector pin out detail – 19 Way:</p> <table border="0"> <tr><td>Pin 1. Dark Blue</td><td>Pin 11. Dark Green</td></tr> <tr><td>Pin 2. Pink</td><td>Pin 12. Red</td></tr> <tr><td>Pin 3. Violet</td><td>Pin 13. Lavender</td></tr> <tr><td>Pin 4. Light Blue</td><td>Pin 14. Dark Grey</td></tr> <tr><td>Pin 5. Orange</td><td>Pin 15. Black</td></tr> <tr><td>Pin 6. Light Green</td><td>Pin 16. Cream</td></tr> <tr><td>Pin 7. Burgundy</td><td>Pin 17. White</td></tr> <tr><td>Pin 8. Turquoise</td><td>Pin 18. Dark Brown</td></tr> <tr><td>Pin 9. Yellow</td><td>Pin 19. Light Brown</td></tr> <tr><td>Pin 10. Light Grey</td><td></td></tr> </table>	Pin 1. Dark Blue	Pin 11. Dark Green	Pin 2. Pink	Pin 12. Red	Pin 3. Violet	Pin 13. Lavender	Pin 4. Light Blue	Pin 14. Dark Grey	Pin 5. Orange	Pin 15. Black	Pin 6. Light Green	Pin 16. Cream	Pin 7. Burgundy	Pin 17. White	Pin 8. Turquoise	Pin 18. Dark Brown	Pin 9. Yellow	Pin 19. Light Brown	Pin 10. Light Grey	
Pin 1. Red	Pin 5. Green																																											
Pin 2. Black	Pin 6. Orange																																											
Pin 3. White	Pin 7. Blue																																											
Pin 4. Yellow																																												
Pin 1. Pink	Pin 8. Grey																																											
Pin 2. Orange	Pin 9. Black																																											
Pin 3. Dark Blue	Pin 10. Yellow																																											
Pin 4. Dark Brown	Pin 11. Violet																																											
Pin 5. Red	Pin 12. Light Brown																																											
Pin 6. Light Green	Pin 13. White																																											
Pin 7. Dark Green	Pin 14. Light Blue																																											
Pin 1. Dark Blue	Pin 11. Dark Green																																											
Pin 2. Pink	Pin 12. Red																																											
Pin 3. Violet	Pin 13. Lavender																																											
Pin 4. Light Blue	Pin 14. Dark Grey																																											
Pin 5. Orange	Pin 15. Black																																											
Pin 6. Light Green	Pin 16. Cream																																											
Pin 7. Burgundy	Pin 17. White																																											
Pin 8. Turquoise	Pin 18. Dark Brown																																											
Pin 9. Yellow	Pin 19. Light Brown																																											
Pin 10. Light Grey																																												

Pogo Contact Technology



- 1. Contact interface
- 2. Spring
- 3. Spring contact
- 4. Cut away for clarity
- 5. Cable crimp area

The heart of the Nemesis High Mating, Quick Term & Super Clean connector solutions is ITT's unique spring probe pin/pad contact system. ITT's spring probe contact design utilizes an internal clip mechanism that stays in constant contact with the contact itself. This design helps to reduce electrical resistance. In addition, the spring probe contact system accommodates misalignment issues, making the contact system much more forgiving. This feature along with the high durability of mating cycles allows this contact system to offer higher performance in harsh environments.

The unique ITT spring probe system mates with individual touch pad contact areas. This design allows for a very effective electrical engagement point of contact. Further, the spring probe contact system and touch pads allow for ease of cleanability in the field where dirt, moisture, mud, sand, and other contaminants may be present. The individual touch

pad contacts incorporate no crevices for contaminants to accumulate, a desirable feature in harsh environment field conditions.

The Nemesis High Mating, Quick Term & Super Clean connectors using spring probe contact technology offer the highest reliability for interconnects meeting the toughest performance standards in harsh environments. They have been tested through extensive Military and customer specific test programs to ensure that their design and manufacturability features have indeed met all reliability and field performance requirements. Because ITT's spring probe contact/connectors have been designed and manufactured to exceed various thermal shock, vibration, random shock, and signal performance spectrums this connector technology is becoming one of the technologies of choice in harsh environment electronic systems.

Nemesis Twist Pin Contact Technology



- 1. Welded Tip
- 2. Wire bundle
- 3. + 4. Crimp area
- 5. Sleeve
- 6. Wire

The Nemesis Water Tight connector uses the twist pin contact system. This system was originally developed in the early 1960s and ITT was one of the original interconnect companies to license this technology and improve it. Our forty-five years of experience in manufacturing and establishing a fully automated manufacturing system for this contact has truly given ITT the foremost knowledge in twist pin contact technology.

As the core of the Water Tight connector, the twist pin contact offers a superior electrical and mechanical system that outperforms traditional machined or stamped electrical contact systems. ITT's twist pin system consists of the Micro Socket and the Micro Pin or Twist Pin.

The twist pin contact system consists of several stranded cores making up the wire bundle. The strands are subsequently heat treated and a weld is performed on the tip of each contact. Crimp sleeves are then inserted over the contact and crimp areas are defined to produce a seamless crimp system. The entire twist pin system is referred by ITT

as a Pos-A-Line contact alignment system. Our reference to this system identifies that the flexible twist pin is recessed into the insulator and the rigid socket is exposed thus reversing the traditional positions of the pin and socket. During the mating sequence, the socket is guided into the pin insulator by the lead-in chamfer. The pin is kept from flexing beyond the socket capture radius by the walls of the cavity. The hemispherical weld of controlled radius at the tip of the pin combines with the lead-in chamfer of the socket contact and the pin insulator to cam the pin into alignment. ITT has developed a very robust Six Sigma manufacturing process that controls the welding process as well as the dimensions of the socket contact and insulator material. The net result is a contact system that makes it impossible for the recessed pin to escape the socket capture radius.

The advantages of ITT's twist pin contact system are many and have been field proven in the most demanding applications and environments for over forty-five years.

ITT Cannon

ITT Corporation is a diversified leading manufacturer of highly engineered critical components and customized technology solutions for industrial end-markets in energy infrastructure, electronics, aerospace and transportation. Building on its heritage of innovation, ITT partners with its customers to deliver enduring solutions to the key industries that underpin our modern way of life. Founded in 1920, ITT is headquartered in White Plains, N.Y., with employees in more than 35 countries and sales from a total of 125 countries, which generated 2014 revenues of \$2.7 billion.

Our connector portfolio remains the most extensive in the industry, offering a reliable and cost effective range of interconnect solutions with the brands of Cannon, VEAM and BIW Connector Systems. Continuous investment in technology and research & development have enabled ITT to provide new, innovative products and solutions to markets including:

- Automotive
- Computer & Consumer Electronics
- Industrial/Instrumentation
- Military & Aerospace
- Oil & Gas
- Telecommunications/Wireless Handheld Devices
- Transportation

When you specify a Cannon, VEAM or BIW Connector Systems connector, you can rely on products that are designed, developed, and manufactured to the highest quality and reliability standards. This tradition of excellence is based on ITT's corporate culture of operating its businesses under the principles of Six Sigma. At ITT, Six Sigma is not just a quality philosophy but a complete corporate culture that drives the entire business. Our Value Based Management and Value Based Product Development systems are two cornerstones that allow for the development of both leadership and product engineering principles, ensuring our industry leading products are developed to the accepted market driven lead times. These principles have allowed ITT to become the market leader in all of our business portfolios.

Six Sigma Manufacturing

ITT Cannon operates manufacturing facilities in the United States, Germany, Italy, Mexico, China and Japan, all of which have particular product area strengths allowing ITT to offer a truly global footprint to our customers. Our facilities are world class and accommodate full vertical integration utilizing the latest manufacturing technologies including:

automated and robotic machining centers, Super Market manufacturing cells, Kanban pull systems, and automated electrical, mechanical, and optical test and inspection equipment. The combination of our manufacturing strength and our advanced manufacturing facilities allows ITT to offer products at market driven prices. Our capabilities, especially in robotics, computerized precision tooling, Kaizen Project Management, Six Sigma tools, and testing, give ITT the most optimized global manufacturing footprint in the interconnect industry.

The Custom Difference

As the industry leader in harsh environment interconnect applications, ITT's world class engineering teams will work directly with our customers to design and develop cost effective solutions for their applications. In many cases we may modify one of our standard designs to ensure a highly reliable solution where timing is critical. Yet, in those cases where a complete custom interconnect solution is required, ITT will work with our customer's Engineers to design an interconnect solution which will be cost effective yet highly reliable. As professional consultants, our Engineering teams will provide a thorough systems and mechanical analysis of any proposed solution. These analyses provide our customers with sophisticated electrical signal and mechanical characterizations to determine the best solution for their application.

RoHS Compliance Information

ITT has implemented a strict parts control plan for all ITT electronics plants worldwide that allows the Cannon, VEAM, and BIW Connector Systems product portfolios to meet the requirements of the European Union Directive 2002/95/EC better known as the Reduction of Hazardous Substances initiative. As appropriate, specific Cannon, VEAM, and BIW Connector Systems products may be ordered with an R prefix number which insures our customers will receive RoHS compliant parts for their commercial electronics applications and equipment. Since most RoHS hazardous substances center around specific metal plating and lead solder coatings, ITT's products for RoHS compliance are available in the following plating finishes: electroless nickel, stainless steel, anodize over aluminum and gold plating. It should be noted that gold plating would be recommended as the replacement for tin-lead solder when ordering board mount connectors.



Product Safety Information

1. MATERIAL CONTENT AND PHYSICAL FORM

Electrical connectors do not usually contain hazardous materials. They contain conducting and non-conducting materials and can be divided into two groups.

- a) Printed circuit types and low cost audio types which employ all plastic insulators and casings.
- b) Rugged, Fire Barrier and High Reliability types with metal casings and either natural rubber, synthetic rubber, plastic or glass insulating materials. Contact materials vary with type of connector and also application and are usually manufactured from either: Copper, copper alloys, nickel, alumel, chromel or steel. In special applications, other alloys may be specified.

CAUTION

2. FIRE CHARACTERISTICS AND ELECTRIC SHOCK

HAZARD

There is no fire hazard when the connector is correctly wired and used within the specified parameters. Incorrect wiring or assembly of the connector or careless use of metal tools or conductive fluids, or transit damage to any of the component parts may cause electric shock or burns. Live circuits must not be broken by separating mated connectors as this may cause arcing, ionization and burning. Heat dissipation is greater at maximum resistance in a circuit. Hot spots may occur when resistance is raised locally by damage, e.g. cracked or deformed contacts, broken strands of wire. Local overheating may also result from the use of the incorrect application tools or from poor quality soldering or slack screw terminals. Overheating may occur if the ratings in the product Data Sheet/Catalog are exceeded and can cause breakdown of insulation and hence electric shock. If heating is allowed to continue it intensifies by further increasing the local resistance through loss of temper of spring contacts, formation of oxide film on contacts and wires and leakage currents through carbonization of insulation and tracking paths. Fire can then result in the presence of combustible materials and this may release noxious fumes. Overheating may not be visually apparent. Burns may result from touching overheated components.

3. HANDLING

Care must be taken to avoid damage to any component parts of electrical connectors during installation and use. Although there are normally no sharp edges, care must be taken when handling certain components to avoid injury to fingers. Electrical connectors may be damaged in transit to the customers, and damage may result in creation of hazards. Products should therefore be examined prior to installation/use and rejected if found to be damaged.

4. DISPOSAL

Incineration of certain materials may release noxious or even toxic fumes.

5. APPLICATION

Connectors with exposed contacts should not be selected for use on the current supply side of an electrical circuit, because an electric shock could result from touching exposed contacts on an unmated connector. Voltages in excess of 30 V ac or 42.5 V dc are potentially hazardous and care should be taken to ensure that such voltages cannot be transmitted in any way to exposed metal parts of the connector body. The connector and wiring should be checked, before making live, to have no damage to metal parts or insulators, no solder blobs, loose strands, conducting lubricants,

swarf, or any other undesired conducting particles. Circuit resistance and continuity check should be made to make certain that there are no high resistance joints or spurious conducting paths. Always use the correct application tools as specified in the Data Sheet/Catalog. Do not permit untrained personnel to wire, assemble or tamper with connectors. For operation voltage please see appropriate national regulations.

IMPORTANT GENERAL INFORMATION

(i) Air and creepage paths/Operating voltage. The admissible operating voltages depend on the individual applications and the valid national and other applicable safety regulations. For this reason the air and creepage path data are only reference values. Observe reduction of air and creepage paths due to PC board and/or harnessing.

(ii) Temperature

All information given are temperature limits. The operation temperature depends on the individual application.

(iii) Other important information

ITT Cannon continuously endeavors to improve their products. Therefore, Cannon products may deviate from the description, technical data and shape as shown in this catalog and data sheets.

ITT Cannon, is a division of ITT Corporation who manufactures the highest quality products available in the marketplace; however these products are intended to be used in accordance with the specifications in this publication. Any use or application that deviates from the stated operating specifications is not recommended and may be unsafe. No information and data contained in this publication shall be construed to create any liability on the part of ITT Cannon. Any new issue of this publication shall automatically invalidate and supersede any and all previous issues.

Product Warranty

Please refer to www.ittcannon.com (General Terms of Sale) for the complete text of ITT Cannon's applicable Terms and Conditions, including Warranty.

This publication is not to be construed as an offer. It is intended merely as an invitation to make an offer. By this publication, ITT Cannon does not assume responsibility or any liability for any patent infringements or other rights of third parties which may result from its use.

Reprinting this publication is generally permitted, indicating the source. However, ITT Cannon's prior consent must be obtained in all cases. "Engineered for life" is a registered trademark of ITT Corporation ©2012. All other trademarks or registered trademarks are property of their respective owners. All data subject to change without notice.

This document does not contain technical data whose export is restricted by the Arms Export Control Act (Title 22, U.S.C., App 2401 et. Seq.)



Connect with your ITT Cannon
representative today or visit us at
www.ittcannon.com

Connect with the experts.

Whether communicating with our soldiers, or with our first responders saving lives, ITT Cannon connects the world's most important information with those who need it.



CHINA—Shenzhen City

+86.755.2726.7888

JAPAN—Kanagawa

+81.462.57.2010

USA—Watertown, CT

+1.860.274.9681

GERMANY—Weinstadt

+49.7151.699.0

KOREA—Seoul

+82.2.7027111

HONG KONG

+852.2732.2720

TAIWAN—Taipei

+886.2.25452020

ITALY—Lainate

+39.02938721

UK—Basingstoke

+44.1256.311200

USA—Orange County, CA

+1.800.854.3028