

Amphenol AMPHE-EX™ Assembly Instructions

L-2124



Document Contents:

- Familiarization & Assembly
- Contact Preparation and Installation
- Connector Assembly
- Part Number Code Logic

For additional information, consult Amphenol AMPHE-EX™ Catalog, 12-056

©Amphenol Corporation, Sidney, NY, USA

Printed in U.S.A. 01/10
Revision C

Amphenol Industrial

AMPHE-EX™

Description of equipment

The Amphe-EX Connectors each comprise a metallic bodied plug or receptacle shell, to form in-line cable connections. Externally the main body is fitted with a suitably certified cable gland. Internally the main bodies each contain an insulator insert fitted with solder type contact pins or sockets. The plug and receptacle shells together form an in-line connector. When connected together they form a spigotted flamepath and are mechanically interlocked by means of a threaded nut retained by a grub screw.

Additionally, the receptacle connector is available in a bulkhead mounted version that contains an externally threaded flamepath for mounting to certified EX enclosures with suitable internal mating thread. This variety must be internally potted, as described within this document.

The range comprises seven body (form) sizes each with a number of pin/socket size combinations between 6 and 79 contacts. The connector shell size, pin configuration and rating are reflected in the individual type designations.

Design Options

Alternative association with flameproof blanking caps on connectors fitted with energised contact sleeves.

Alternative association with environmental blanking caps on connectors with non-energised contact pins.

Alternative keying options.

Alternative pin or sleeve contacts in either the plug or receptacle bodies

Model Code Designations

Connectors: EXM-(a)b-(c-d)(e)(f)(g)

Connector series type designation	EXM
Shell material (a)	A-Aluminium B-Brass S-Stainless steel
Shell configuration (b)	01 - In-line Receptacle comes w/ blanking cap 02 – Bulkhead Mount Receptacle comes w/ blanking cap. 06 – In-line Plug comes w/ blanking cap
Shell size (c)	Either: 9, 11, 13, 15, 17, 19 or 21
Insert arrangement (d)	e.g. 35
Contacts type (e)	P – Pin contacts S – Sleeve contacts
For shell configs 01 & 06 Cable diameter range designation (f)	e.g. A
For shell config 02 Bulkhead adapter type, (f) See table 3, page 13 for thread details.	M – metric N – NPT
Keying position (g)	e.g. 01

Blanking caps: EXM –ab - c

Cap Style (a)	A-Aluminium B-Brass S-Stainless steel
Assembly type (b)	PC - Plug Cap Assy RC - Receptacle Cap Assy
Shell size (c)	Either: 9, 11, 13, 15, 17, 19 or 21

Familiarization & Assembly Information

1. Read manufacturer's assembly instructions before actually starting to assemble connectors. Besides the matter of instruction on correct procedures, there are two important reasons for this preliminary step: To identify the various component parts, and to check for any missing parts.
2. Cut cable jacket and sheathing squarely and sheathing squarely and to correct length, using only wire strippers that have been approved for the operation. In preparing the individual wires in cables and harnesses for assembly, make allowances in length for reaching the outer most circle of contacts cavities in the conductors. The insulation should be cut progressively longer as they extend out from the center of the cable or harness to assure sufficient length.
3. Follow chart on Page 5 covering maximum cable stripping lengths for effective cable gland sealing. All conductors should be fit into contact wire wells correctly. A practice layout should be done so that an assembler can oversee what the finished will look like when finished.
4. Before starting actual termination of wires, it is essential that cables and harnesses be laid out in a specific order in accordance with the wiring diagram. Proper layout will eliminate the need for twisting and crossover of conductors. If the wiring layout is not correct, the termination operation will be difficult or even impossible and the chances for making errors will be increased. Cable and harness assemblies having a spiral layout must also be matched carefully to the correct contacts in both the male and female inserts.
5. Some cables that will be used will have a "basket weave" type of armor under the outer jacket (sheath) and over the inner jacket. Since many regulatory entities require that the armor be grounded at least at the source end, it is beneficial to ground the armor via a spare contact within the connector. Follow the removal of sufficient amount of outer jacket (see chart on Page 5) ample amount of armor can be clipped away, but not all. An adequate amount should remain in order that a small cross-section conductor, short in length, be woven into the remaining armor weave and either soldered or covered with mastic impregnated heat shrink, creating an intimate bond to the armor. At the opposite end of the short piece of wire a contact should be crimped and inserted into the insert.
6. Use only correctly sized and ingress protected certified glands provided to assure resistance to moisture and other contaminates.
7. Use only the proper crimping tools that have been set or calibrated with precision gages.
8. Make certain that all contacts are the correct size before attempting to assemble in insert cavities. This point is particularly important when both power and control types of contacts are used in the same connector.
9. Be sure that any ground contacts (when applicable) are correctly located.
10. Seat all contacts properly so that they will not be damaged or become disengaged during connectors mating operation.
11. Use only the proper insertion tools and be sure that they are aligned axially when pushing contact into their fully seated position.
12. When inserts have more cavities than the conductors, plug unused cavities with furnished contacts.
13. After all terminated contacts are inserted in their respective cavities and inspected (detailed on page 5), the cable adapter should be installed and tightened with a strap wrench (detailed on page 8).
14. When handling cables, use adequate support to prevent damage to the internal wires. Exd glands are intended for sealing purposes and should not be used as a cable grip.
15. If for any reason, terminated conductors have to be removed from an insert because of an assembly error or change in circuitry, be sure to remove the cable gland or cable adapter first before extracting the contact and re-inserting it.
16. If one of the connector poles is a ground wire, make sure that it is grounded properly before the connector actually is engaged.
17. When connectors have the same configuration are to be mounted closer together, different or alternate key arrangements should be used to prevent mismatching and possible damage to the electrical system.
18. Always inspect all aspects of connector assembly operations before putting connector into actual operation.
19. Crimping and terminating of conductors to contacts must be done carefully. Make certain that all wire strands are fully bottomed in contact wells by checking through inspection hole provided (detailed on page 5).
20. Never try to straighten bent contacts. Straightening cannot be done properly and the plating on contacts very likely will be marred. This will result in a high resistance connection and will expose the base material to possible corrosion.
21. Each assembly operator should be his own inspector. Worn, damaged, or defective tools should be reported immediately to foreman and supervisors. Assembly operators should be indoctrinated with this attitude and made to understand the importance of always guarding quality. Assembly workmanship is significant factor in terminating the quality of multiple contact connectors. Quality cannot be "inspected" into connectors; it must be "built-in" during each and every assembly operation.

**The following instructions apply to equipment covered by certificate numbers:
SIRA 07ATEX1229X & IECEx SIR 08.0029X.**

The equipment may be used with flammable gases and vapours with apparatus group(s) IIA, IIB, & IIC and with temperature classes T6, T5, T4, T3, T2 & T1.

The equipment is only certified for use in ambient temperatures in the range -20°C to +40°C and should not be used outside this range.

The product complies with the following standards:

- EN 60079-0:2006 General requirements for electrical apparatus for explosive gas atmospheres (IEC 60079-0:2007 5th Ed)
- EN 60079-1:2007 Electrical apparatus for explosive gas atmospheres - Part 1: Flameproof enclosures "d" (IEC 60079-1:2007 6th Ed)
- EN 60079-7:2007 Electrical apparatus for explosive gas atmospheres –Part 7: Increased safety "e" (IEC 60079-7:2006 4th Ed)
- EN 61241-0:2006 General requirements for electrical apparatus for use in the presence of combustible dust (IEC 61241-1:2004 1st Ed + Corr Nov 05)
- EN 61241-1:2004 Electrical apparatus for use in the presence of combustible dust. Protection by enclosures “tD” (IEC 61241-1:2004 1st Ed)

Installation shall be carried out by suitably-trained personnel in accordance with the applicable code of practice **e.g. EN/IEC 60079-14 or EN/IEC 61241-14**. It is the end user’s responsibility to ensure that the product, as specified and confirmed by the product label, is suitable for its intended application.

Inspection and maintenance of this equipment shall be carried out by suitably trained personnel in accordance with the applicable code of practice e.g. **EN/IEC 60079-17 or EN/IEC 61241-17**.

Repair of this equipment shall be carried out by suitably trained personnel in accordance with the applicable code of practice e.g. **EN/IEC 60079-19**.

Components to be incorporated into or used as replacement parts of the equipment shall be fitted by suitably trained personnel, using only components purchased from Amphenol or an Amphenol approved distributor. Any use of non-approved components/suppliers will invalidate the certification for that product.

The certification of this equipment relies upon the following materials used in its construction:

- 1) Connector Materials:
 - a. (Standard Base Material) ASTM B211 or B221 Alloy 6061-T6, Aluminum (<7%Mg),
 - b. (Optional Base Material) ASTM 5640, Alloy 303, Stainless Steel
 - c. (Optional Base Material) ASTM B455, Alloy C38500, Brass
- 2) O-ring Seal Material: Buna Rubber w/ Durometer of 70 SHORE A

If the equipment is likely to come into contact with aggressive substances, then it is the responsibility of the user to take suitable precautions that prevent it from being adversely affected, thus ensuring that the type of protection provided by the equipment is not compromised.

Aggressive substances: e.g. acidic liquids or gases that may attack metals, or solvents that may affect polymeric materials.

Suitable precautions: e.g. regular checks as part of routine inspections or establishing from the material's data sheets that it is resistant to specific chemicals.

SPECIAL CONDITIONS FOR SAFE USE/CONDITIONS OF CERTIFICATION

The following must be adhered to in full for safety and as to not invalidate product certification.

- When a Connector half fitted with contact pins is not connected to an associated Plug or Receptacle, it shall not be energised, as per EN 60079-0:2006, clause 20.2.
- When a Connector half fitted with contact sleeves is not connected to an associated Plug or Receptacle, it shall not be re-energised unless it is fitted with an explosion-proof-blanking cap.
- Plugs and receptacles shall only be used with blanking caps or mating Connector halves certified under the same certificate number either: IECEx SIR 08.0029X or SIRA 07ATEX1229X
- This connector does not incorporate an internal or external earth facility, it is therefore the responsibility of the user/installer to provide adequate earth continuity using the guidance given in the manufacturer's installation instructions.
- The user installed conductors fitted to the panel mount receptacles shall be suitable for a continuous operating temperature of at least 44°C and rated for an ambient of at least 40°C.
- The user installed conductors fitted to the panel mount receptacles are to be insulated between connection to the receptacle contacts and associated terminals within associated enclosures to which they are fitted.
- The panel mount receptacles shall only be used where the temperature at the point of entry in service on the associated enclosure is between -20°C to +83.5°C.
- The interface between the panel mount receptacles and associated increased safety enclosure to which they may be fitted cannot be defined. Therefore it is the user's responsibility to ensure that the appropriate ingress protection level of the associated enclosure is maintained at this point.

Contact Preparation Instructions

I. Crimp Tools:

1. M22520 Series is recommended. See Tool Table in catalog, for choice of turret head and selection setting according to contact size, part number and wire gage size.
2. Setting Up and Operation: Consult Tool Manufacturer.

II. Wire Preparation and Crimping

1. Strip wire to required length. (See Figure 1). When using hot wire stripping do not wipe melted insulation material on wire strands; with mechanical strippers do no cut or nick strands.

Figure 1

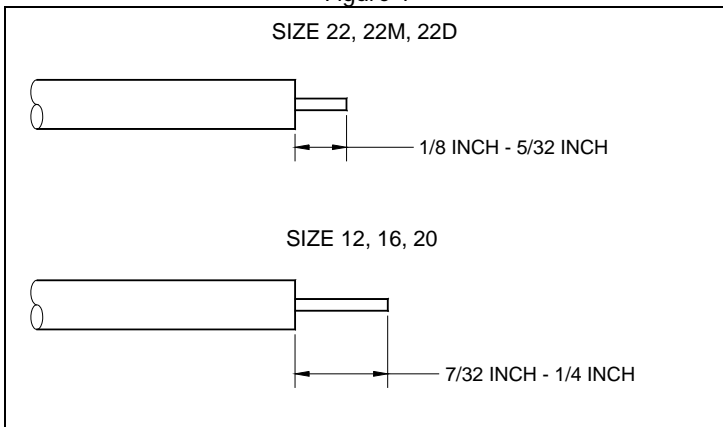

2. See Table 1 for proper finished outside wire dimensions.

Contact Size	Wire Diameters (in.) **	
	Min.	Max.
10	0.135	0.162
12	0.097	0.142
16	0.065	0.109
20	0.040	0.077
22	0.034	0.060
22M, 22D	0.030	0.050

**Min. diameters to insure moisture proof assembly; max diameters to permit use of metal removal tools. Twist Strands together to form a form bundle.

3. Insert stripped wire into contact applying slight pressure until wire insulation butts against wire well. Check inspection hole to see that wire strands are visible. If there are strayed wire strands, entire wire end should be re-twisted.
4. Insert wire and contact into crimping tool as far as possible. Crimp contact wire well.

III. Contact Insertion and Removal

1. When inserting or removing contacts, first remove securing devices and slide devices over wires in proper sequence
2. Consult Tool Table, in catalog, for correct insertion or removal tool (metal or plastic) according to contact size.
3. Insertion:
 - a. Slip correct size tool (with plastic tool, use colored end) over wire insulation and slide forward until tool bottoms against rear contact shoulder. Contact must be aligned with grommet hole and not inserted at an angle. Push forward until contact is felt to snap into position within insert. Remove tool, holding forward on the wire in order to prevent contact from being dragged back with tool. Gently pull each wire to ensure contact is properly seated.
 - b. Uncrimped Contacts and Sealing Plugs: Fill in unused holes with an uncrimped contact. Follow with a teflon sealing plug, small diameter first, so that one end protrudes out the rear of grommet. See Table 2 for sealing plug application data. (Optional insertion of large end first is possible, but not recommended).

Contact Size	Color Code	Part Number
10	Green	M85049/81-10
12	Yellow	MS27488-12
16	Blue	MS27488-16
20	Red	MS27488-20
22, 22M, 22D	Black	MS27488-22

Slide securing devices forward and tighten using connector pliers. Connector holding tools are recommended while tightening back accessories.

CAUTION: WHEN INSERTING OR REMOVING CONTACTS, DO NOT SPREAD OR ROTATE TOOL TIPS.

IV. Removal:

- c. Slip correct sized tool (with plastic tool, use white end) over wire insulation and slide forward on wire until tool tip enters rear grommet and comes to a positive stop on contact shoulder. Grip wire, and simultaneously remove tool, contact and wire. (On occasion, it may be necessary to remove tool, rotate 90° and reinsert).
- d. Unwired Contacts: Remove sealing plugs. Standard Removal Tools: Using applicable removal tool, insert and carefully work tool tips over wire well. When tips bottom, contact will release from internal retention clip. Push contact from connector front face out connector rear with round ended non-metallic rod. Rod will follow contact. (See Tool Table 3 for applicable removal tool and correct rod diameter). Unwired Removal Tool (11-10050-XX): Removal procedure is same as with standard tools with the exception that tool will withdraw contact without pushing from front. Push plunger to remove contact from tool. (See Tool Table, in catalog, for correct size).

Amphe-EX

insert arrangements

(TYPICAL)

front face of pin inserts illustrated

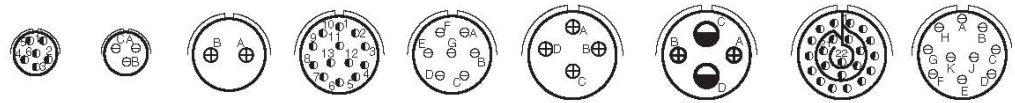

Insert Arrangement	9-35	9-98	11-2	11-35	11-99	13-4	13-13	13-35	13-98
Service Rating	M	I	I	M	I	I	I, Fiber Optic	M	I
Number of Contact	6	3	2	13	7	4	2 2	22	10
Contact Size	22D	20	16	22D	20	16	16 12	22D	20

Dedicated to
Fiber Optics

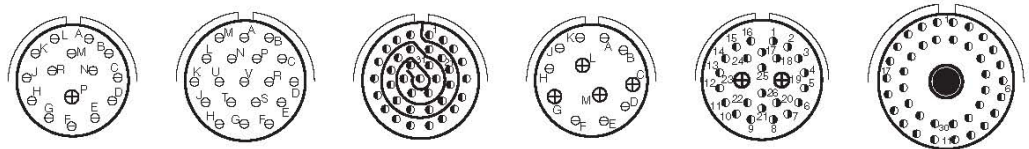

Insert Arrangement	15-15	15-19	15-35	15-97	15-AC	17-2
Service Rating	I	I	M	I	M	M
Number of Contacts	14 1	19	37	8 4	24 2	38 1
Contact Size	20 16	20	22D	20 16	22D 16	22D 8 Twinax

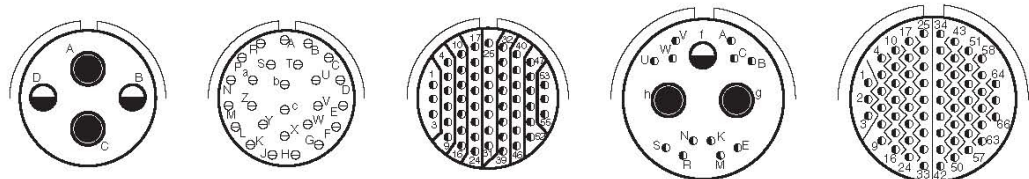

Insert Arrangement	17-22	17-26	17-35	19-31	19-35
Service Rating	Coax	I	M	M	M
Number of Contacts	2 2	26	55	2 1 12	66
Contact Size	12 Coax 8 Coax	20	22D	8 Coax 12 22D	22D

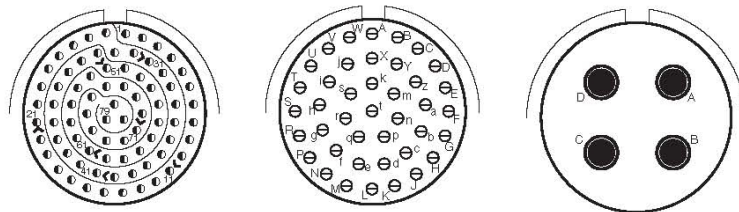

Insert Arrangement	21-35	21-41	21-75
Service Rating	M	I	M
Number of Contacts	79	41	4
Contact Size	22D	20	8 Coax



Connector Assembly Instructions

Assembling a Inline Plug and Inline Receptacle Connectors

- 1) Slide the Cable Gland onto the cable about 12", threaded end last.
- 2) Slide the Cable Adapter onto the cable, up to the Cable Gland, large diameter first.
- 3) Slide the Coupling nut onto the cable, up to the Cable Adapter, Grub Screw end first.
- 4) Group all conductors according to size to facilitate orderly termination.
- 5) Working on one conductor at a time, strip the insulation off per the wire stripping length given in Figure 1 on Page 2, and terminate a contact to it, using a properly adjusted crimp tool, following crimp instruction found in section II on page 2. Repeat the process for each conductor.
- 6) Make sure the Grub Screws are fully retracted, then slide the Coupling Nut up onto the Plug Shell, until seated against its mating shoulder.
- 7) Apply thread-lock compound (Loc-tite 242, blue, or equal) to the threads on the Plug Shell, per the compound manufacturers' recommendations.
- 8) Thread the Cable Adapter onto the Plug Shell, hand-tighten, and then wrench fully to shoulder using a strap wrench. The Plug Shell can be restrained during this procedure, by mating it with a Panel Mount Receptacle Shell that is held in a table mounted vise.
- 9) After hand tightening the Ex Gland onto the Cable Adapter, refer to Amphenol's EX-35/EX-45 Cable Gland Fitting Instructions, for instruction on complete securement of the Cable Gland to the cable adapter, and seal compression around the cable jacket. In terms of the Amphe-Ex series, the "Cable Adapter" is considered an "enclosure", and should be treated as such, where referenced in the Gland Fitting Instructions.
- 10) NOTE ON GROUNDING:
 - a. Internal earthing is provided as applicable via use of available contact pin/sleeve(s) as earthing facilities.
 - b. External earthing is provided via the flange on the receptacle, providing a connection point for external earthing hardware/fasteners, as applicable and to be provided by the end user. However, the equipment is intended to be utilised with cables incorporating an earthing conductor, or a braided shield, which is to be terminated and used as an earth conductor.
- 11) NOTE ON INGRESS PROTECTION:
 - a. Outside of the certification standards, the product has been assessed suitable for an IPx8 rating; tested at a depth of 10 meters for 30 minutes.
 - b. If an IPx8 rating is a requirement, it is to be specified at the placement of order to assure that the correct ingress rated cable gland is provided as a component of the connector assembly.

Preparing a Bulkhead Receptacle Connector for Enclosure Mounting.

- All receptacle shells have, contained within them, contact retaining insulators that are permanently installed by the factory.
- 1) Restrain the Receptacle Shell by holding it in a table mounted vise, using a judicious amount of pressure to secure it, without damaging the flange.
 - 2) Slide the Bulkhead Adapter up onto the cable, or conductor group; knurled end first.
 - 3) Terminate each conductor with its proper contact.
 - 4) Populate the insert with contacts by poking each of the wired contacts into its respective insert cavity, following an electrical schematic for the system being wired.
 - 5) Slide the Bulkhead Adapter back down the conductors, apply thread locking compound (Loc-tite 242, blue, or equal), per the compound suppliers recommendations.

- 6) Hand-tighten the Bulkhead Adapter onto the Panel Mount Receptacle Shell, then, using a strap wrench, tighten the Bulkhead Adapter fully to shoulder.
- 7) Referring to the Potting Instructions, Pg 10, stand the assembly vertical, conductors pointing up, and fill the Potting Adapter with cement to the level shown in Figure Z. After curing, this assembly is now permanently cemented, non-separable and non-repairable, and can be mounted to the bulkhead.
- 8) It is best to fit the connector to the bulkhead at a time when the free end of the cable is not terminated to the electrical system. If this is not possible, then it is necessary to rotate the connector assembly counter-clockwise to wind the cable/conductors so that when the assembly is threaded into a bulkhead in the subsequent instruction, the cable/conductors regain their most natural lay, once the connector is mounted to the bulkhead. (Rotations required to be determined by end-user).
- 9) Thread the receptacle assembly into the bulkhead until the seal touches down, and then tighten it by the smallest fraction of a revolution to the first instance that the mounting holes line up with the threaded enclosure holes.
- 10) Position the protective covers' lanyard tab over one of the mounting holes and screw a fastener through it. Apply the remaining fasteners to the other three holes with torque suitable for screw size used.
- 11) Install the protective cover and tighten fully.
- 12) Secure both grub screws to prevent unauthorized removal.

AMPHE-EX™ Potting Instructions

All cable adapters, other than ones suited for mating with an EX-certified gland, must be filled with epoxy (potted). The material certified for use in filling the connectors in this series, is Resinlab # EP1056LV. The user or installer shall consider the performance of these materials with regard to attack by aggressive substances that may be present in the hazardous area. This material is a two-component casting system with a 2A:1B volumetric mix ratio. The product is available in pre-measured "mix & dispense" packaging. More information is available by contacting the following authorized suppliers:

Amphenol Industrial Operations
40-60 Delaware Avenue
Sidney, New York 13838 USA
Phone (607) 563-5011

Amphenol Industrial Operations Optimize Nogales
180 N Freeport Drive
Nogales, AZ 85621
Phone: 520-397-7053

Amphenol Technology Industrial Operations-Shenzhen
BLK 4 Fuan 2nd Industrial Park
Dayang Road Fuyong Baoan
Shenzhen China
Phone: 86 755 2991 8389

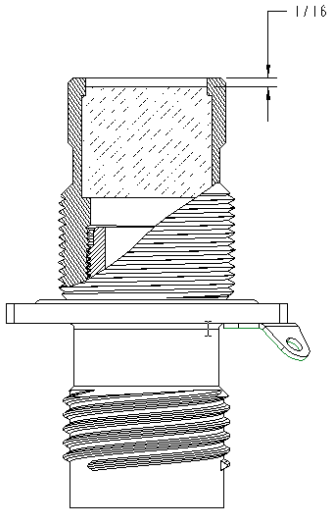

Bulkhead Adapter

Bulkhead adapters should be filled to a minimum of 1/16” below the top of the adapter, as shown. Potting flush with end of adapter is acceptable. Care must be exercised so that the potting compound does not contaminate the bulkhead threads, or spill onto the surfaces of the receptacle flange.

In preparation for potting, the receptacle is to be mated to its corresponding plug, so that all contacts are mated and in their optimal post-potted position. During the potting process, the receptacle connector should be rigidly fixtured in a vertical position, by its flange, as shown. This fixture must be capable of holding the mated connector pair in that position for a minimum of 12 hours at room temperature. The exiting conductor/cable should be fixtured inline and above the connector pair, during the entire 12 hour set time, without disturbance.

Mixing/Potting Instructions

1. CAUTION: Wear goggles or other eye protection during all operations.
2. The potting compound is pre-measured in Twinpak (Rod & Clip) packaging. This packaging consists of a single plastic bag that is compartmentalized into two chambers, each containing one part of the two part compound. The segregating device is called a ‘Rod & Clip’.
3. Carefully remove the outer poly or foil bag without puncturing the inner Twinpak.
4. Separate the plastic rod from the plastic clip, and discard.
5. Mix the entire contents of the bag, by alternately squeezing the bags contents, and working the bag across the edge of a table, to fully move the entire contents of the bag, back and forth, between chambers. Work the material in this manner, constantly, for a minimum of 40 to 50 times. This should take about 2 minutes.
6. If you see striations, or non-uniform color throughout the Twinpak, mix an additional 10-15 times.
7. Once mixed, squeeze all the contents away from one corner of the bag, fully clearing that corner of the bag of all compound.
8. Make a 3/16” pouring spout by snipping off the bags cleared corner. Epoxy must be poured within 10 minutes of mixing.
9. To minimize air entrapment, slowly pour the compound into the back end of the bulkhead adapter, to a level shown in Figure Z.
10. Avoid getting epoxy onto the sides of the adapter, with particular attention to the threaded area. Epoxy in the threads will impede assembly with the bulkhead.
11. Set the bag containing the remaining compound aside, so that it may cure. After cure, the bag may be disposed of safely, along with common consumer refuse. CAUTION: As the remaining compound cures, the bag will become warm.

** WARNING: The receptacles shall only be used where the temperature at the point of entry in service on the associated enclosure is between -20°C to +83.5°C. **

Epoxy Volume Per Bulkhead Adapter

Shell Size	Fill Length inside Adapter (inches)	Adapter Diameter (inches)	Internal Volume (in ^ 3)	Internal Volume* (ounces)
9	1.3	0.652	0.434	0.24
11	1.3	0.652	0.434	0.24
13	1.3	0.927	0.877	0.49
15	1.3	0.927	0.877	0.49
17	1.3	1.242	1.575	0.87
19	1.3	1.242	1.575	0.87
21	1.3	1.242	1.575	0.87

Note: * Minimum amount of potting required.

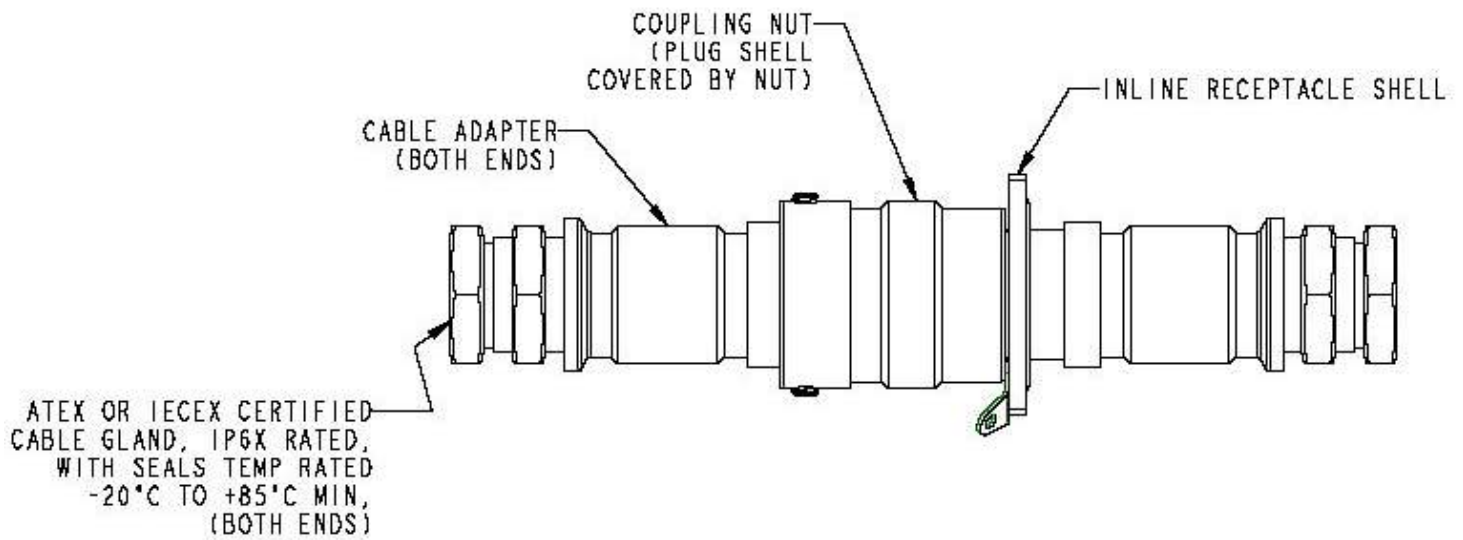

Figure 1: Inline Configuration: Plug mated to Receptacle.

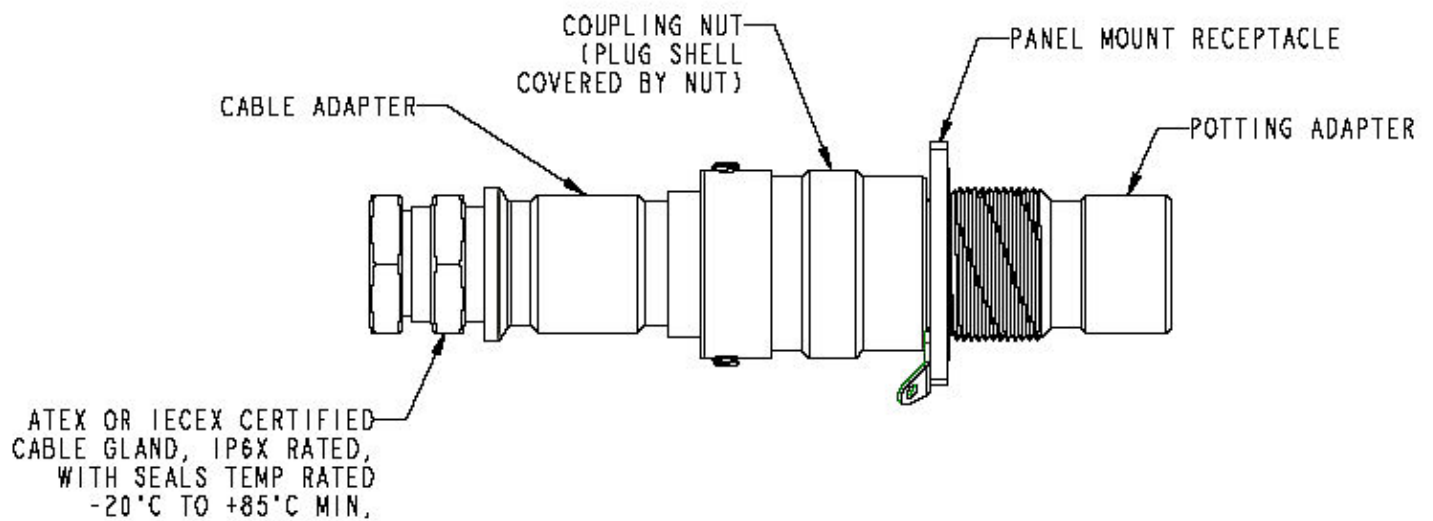

Figure 2: Panel Mount Configuration: Inline Plug mated to Bulkhead Receptacle.

Panel Mount Recept Part #	Threaded Spigot Size (Metric adapter ver) (6 threads min.)	Threaded Spigot Size (NPT adapter)
EXM-(a)02 -(9-d)(e)(f)(g)	M25x1.5-6g	3/4" NPT
EXM-(a)02 -(11-d)(e)(f)(g)	M25x1.5-6g	3/4" NPT
EXM-(a)02 -(13-d)(e)(f)(g)	M32x1.5-6g	1" NPT
EXM-(a)02 -(15-d)(e)(f)(g)	M32x1.5-6g	1" NPT
EXM-(a)02 -(17-d)(e)(f)(g)	M40x1.5-6g	1-1/4" NPT
EXM-(a)02 -(19-d)(e)(f)(g)	M40x1.5-6g	1-1/4" NPT
EXM-(a)02 -(21-d)(e)(f)(g)	M40x1.5-6g	1-1/4" NPT

Table 3: Bulkhead Mount Threaded Spigot, Size and Type.

SIRA Product Labeling Information

Information below must be attached to connectors via non-removable label.

Amphenol Industrial
Sidney NY 13838 USA

Part Number, Revision

"Max Volts, Max Amps, Current Rating per pin"

Date of Manufacture and Date Code



0518



II 2 GD

Ex d IIC T6 Gb / Ex tb IIIC Db IP6X
Ex de IIC T6 Gb / Ex tb IIIC Db IP6X

(for Inline Plugs, and Inline Receptacles)
(for Bulkhead Mount Receptacles)

SIRA 07ATEX1229X
IECEX SIR 08.0029X

Warnings:

Do not open when an explosive gas or dust atmosphere is present.
Do not separate while energised.
Supply conductors shall be suitable for a cont. oper. temp. of at least 90°C.